

Einbauanleitung  
 Mounting instruction  
 Montagehandleiding  
 Instructions de montage  
 Istruzioni di montaggio

Poresta® BF 70

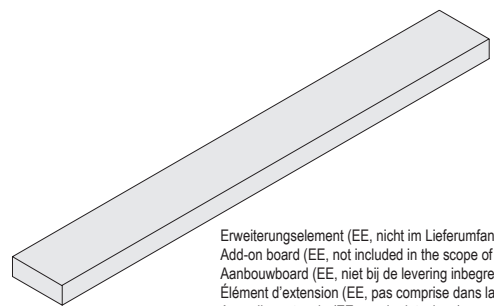

Erweiterungselement (EE, nicht im Lieferumfang)  
 Add-on board (EE, not included in the scope of supply)  
 Aanbouwboard (EE, niet bij de levering inbegrepen)  
 Élément d'extension (EE, pas comprise dans la fourniture)  
 Asse di montaggio (EE, non in dotazione)

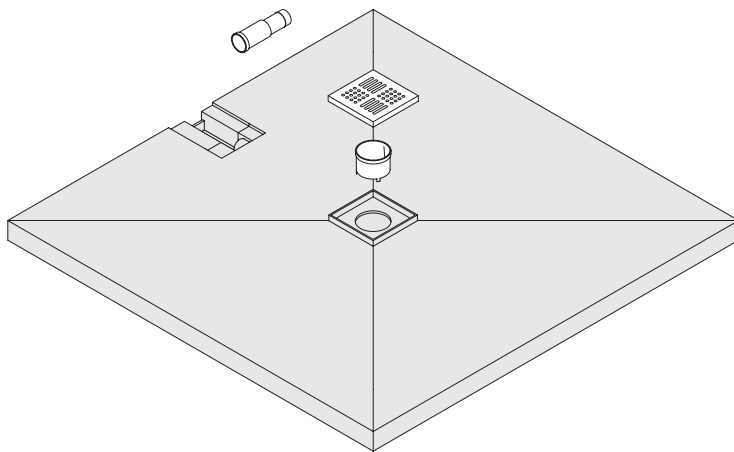
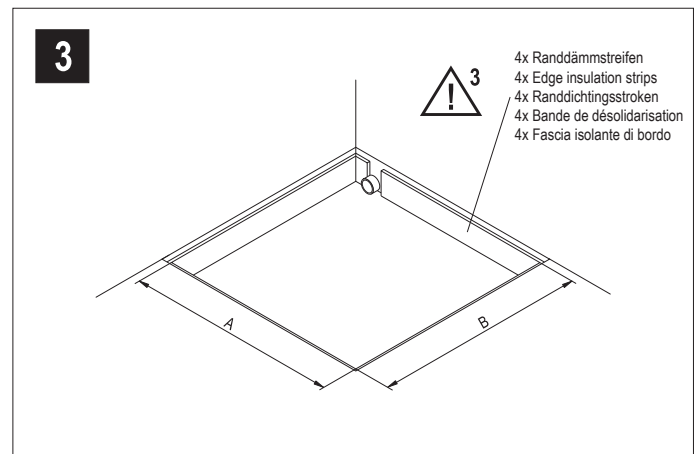
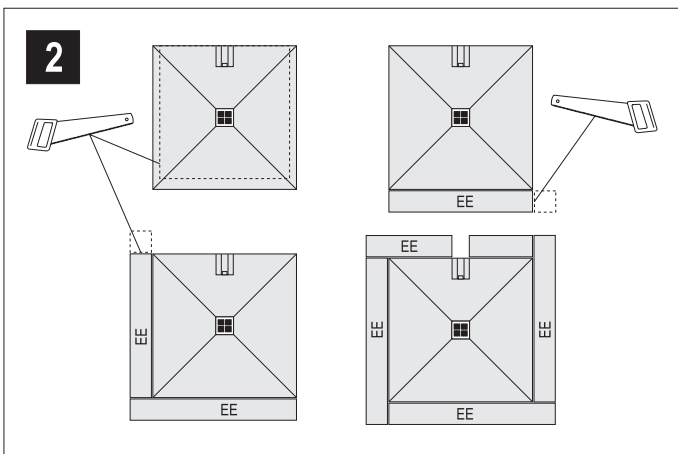
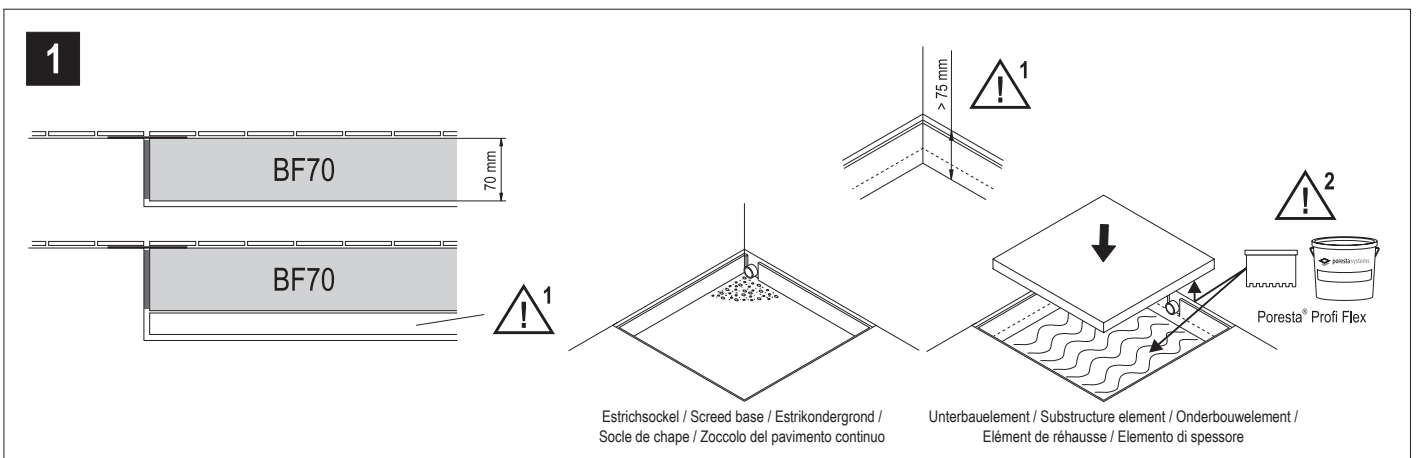

Einbauanleitung  
 Mounting instruction  
 Montagehandleiding  
 Instructions de montage  
 Istruzioni di montaggio

Poresta® BF 70

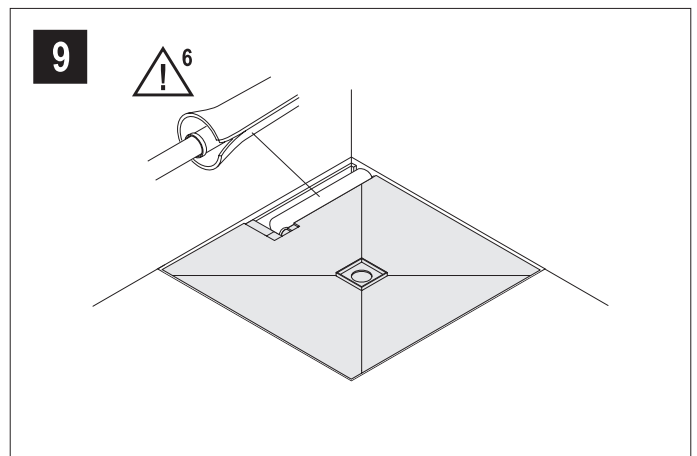
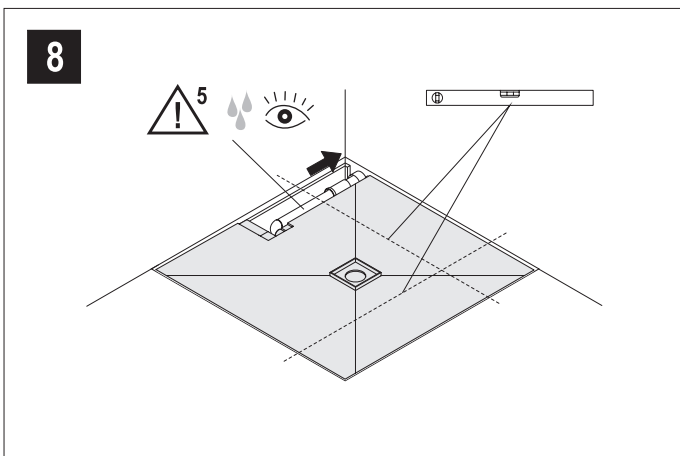
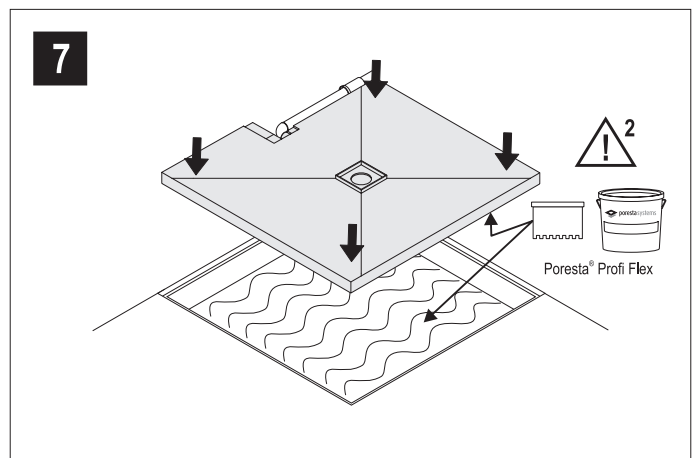
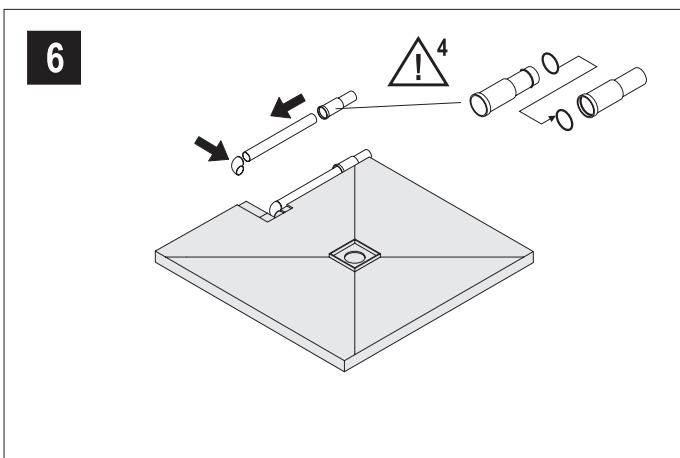
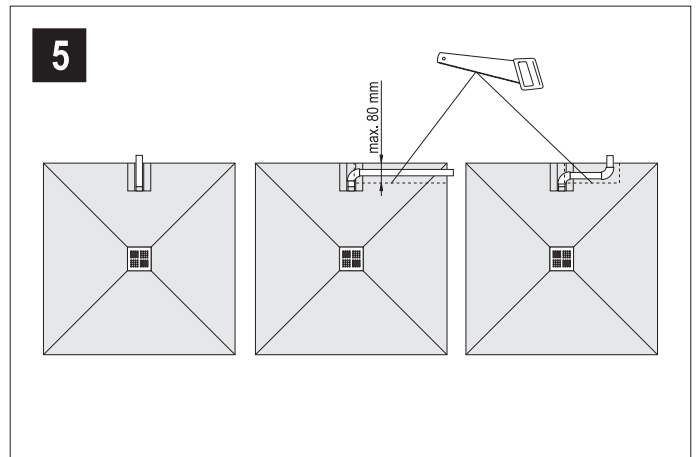
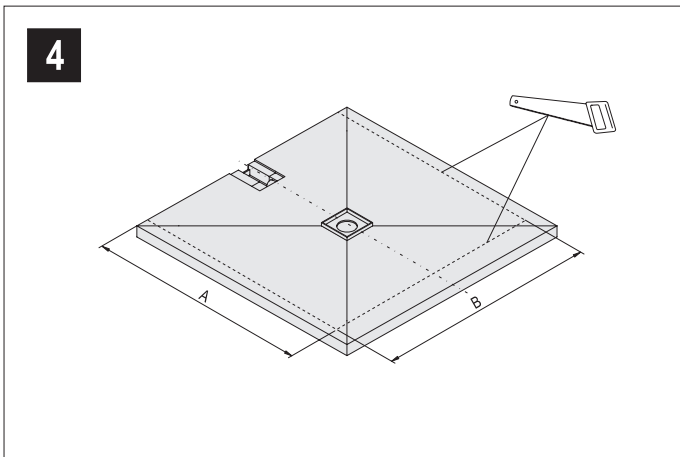

**Einbauanleitung  
Mounting instruction  
Montagehandleiding  
Instructions de montage  
Istruzioni di montaggio**

Poresta® BF 70

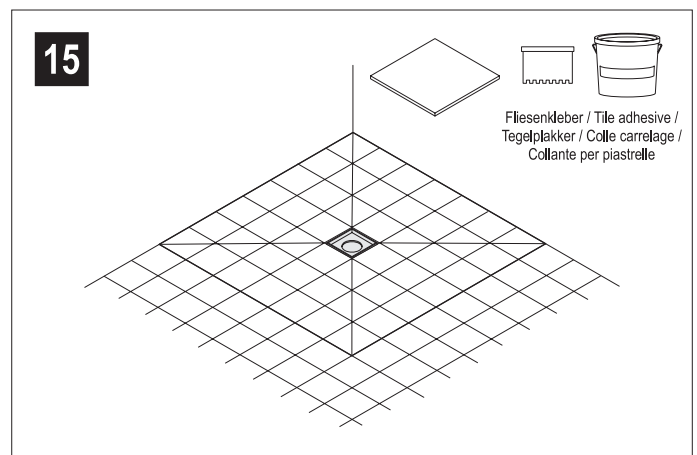
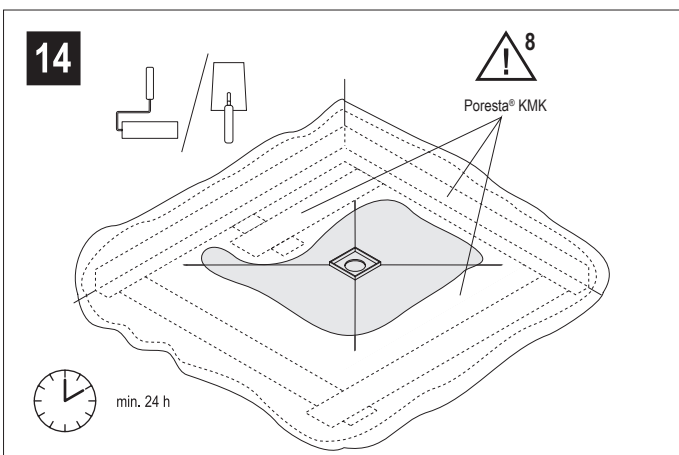
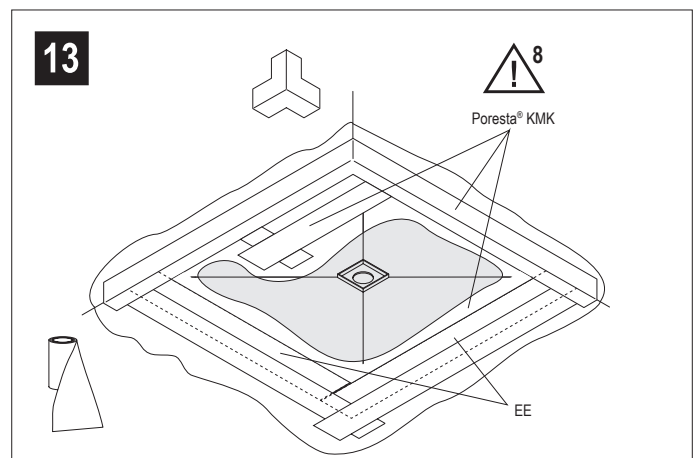
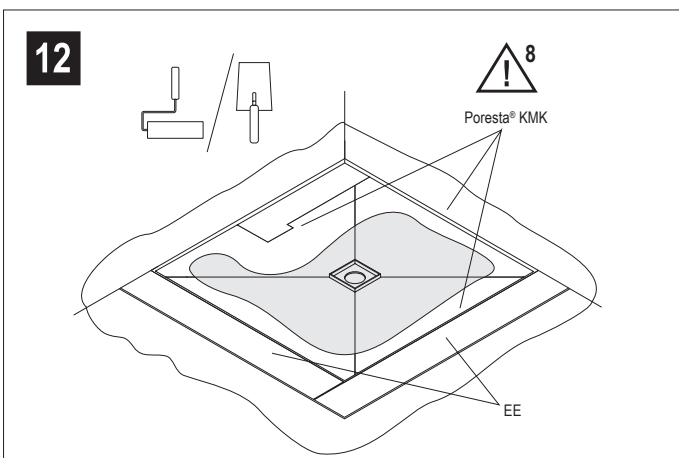
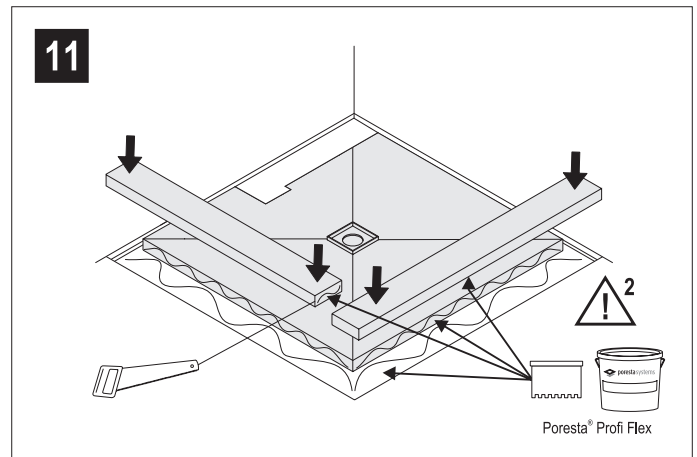
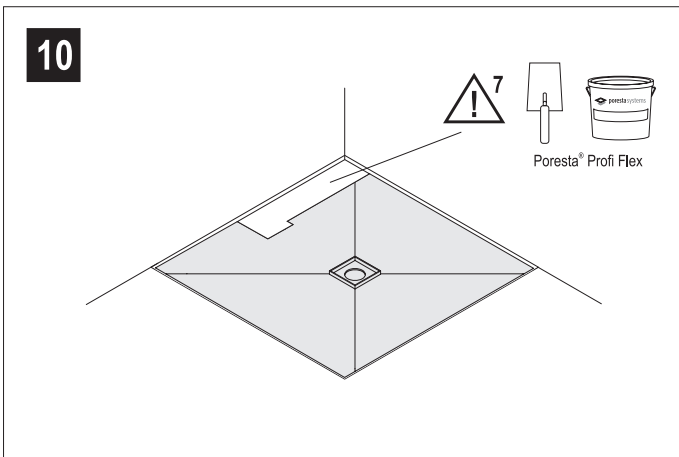

**Einbauanleitung**  
**Mounting instruction**  
**Montagehandleiding**  
**Instructions de montage**  
**Istruzioni di montaggio**

Poresta® BF 70

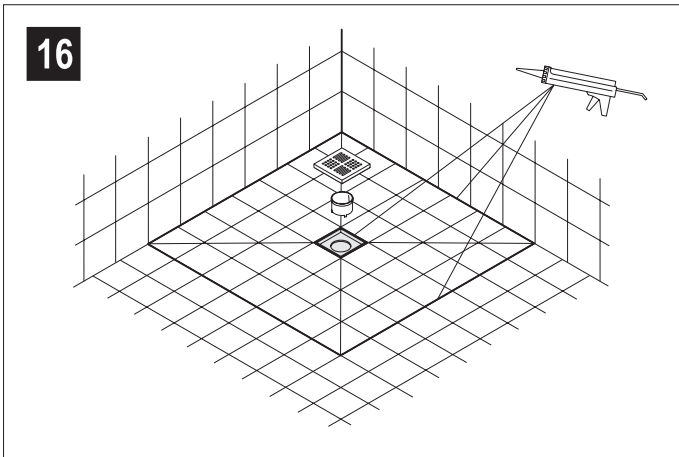

# Einbauanleitung

## Mounting instruction

## Montagehandleiding

## Instructions de montage

## Istruzioni di montaggio

### Verwendung:

- Das Duschsystem Poresta® BF 70 kann vom Verarbeiter unter Berücksichtigung der Größe, Einbauhöhe und der Geometrie des Duschsystems seitlich und gegenüberliegend zum Ablauf variabel bis auf 900 x 700 mm gekürzt werden.
- Die Art und Weise der Nutzung des Duschplatzes (Spritzschutz, Bewegungsfläche etc.) ist zu berücksichtigen.
- Für den Einbau des Duschsystems muss ein ebener, sauberer, tragfähiger, schwingungsfreier und für die Verklebung mit Poresta® Profi Flex geeigneter Untergrund vorhanden sein.
- Das Duschsystem ist generell rollstuhlbefahrbar unter Verwendung von Fliesen mit einer Mindestgröße 100 x 100 mm. Bei Einarbeitung eines Glasgewebes in das Fliesenkleberbett können auch Fliesen mit einer Mindestgröße 50 x 50 mm verwendet werden.
- Nur für den Einsatz im Innenbereich geeignet.

 Die einschlägigen Verarbeitungsrichtlinien aller beteiligten Gewerke sind zu berücksichtigen.

 **1** Beim Einbau (Estrichhöhe >75 mm) müssen Unterbauelemente (nicht im Lieferumfang) oder ein gegossener Estrichsockel verwendet werden.

 **2** Poresta® Profi Flex beidseitig auftragen. Werden Erweiterungselemente verwendet, ist Poresta® Profi Flex auch auf den Stirnseiten des BF 70 sowie den Erweiterungselementen aufzutragen.

 **3** Randdämmstreifen sind bauseits zu stellen.

 **4** Dichtring von der Steckverbindung entfernen und in die Muffe einsetzen.

 **5** Nach Installation der Ablaufgarnitur ist eine Dichtigkeitsprüfung durchzuführen.

 **6** Vor Verschließen des Ablaufkanals eine geeignete Wärme- und Schallschutzummantelung an der Ablaufleitung anbringen.

 **7** Verschließen des Ablaufkanals mit Poresta® Profi Flex. Poresta® Profi Flex standfest anrühren. Die Verarbeitungshinweise des Herstellers sind zu beachten.

 **8** Die Verarbeitungshinweise des Poresta® KMK sind zu beachten.

Einbaubeispiel mit Poresta® UBE Unterbauelement:

Aufbauhöhe/Fertigfußboden	100 mm
Poresta® BF 70	-70 mm
2 Lagen Poresta® Profi Flex	-10 mm
Poresta® UBE Unterbauelement	= 20 mm

Das Duschsystem Poresta® BF 70 erfüllt in eingebauten Zustand die Anforderungen an Baustoffe der Baustoffklasse B2 nach DIN 4102-1 (normalentflammbar) der Klasse E nach DIN EN 1350-1.

# Einbauanleitung

## Mounting instruction

## Montagehandleiding

## Instructions de montage

## Istruzioni di montaggio









### Use:

- The shower system Poresta® BF 70 may be variably cut to size by the installer laterally and opposite of the drain in consideration of the size, the installation height and the geometry of the shower system.
- The kind of utilization of the shower space (splash protection, movement area, etc.) is to be considered.
- For the installation of the shower system a level, clean, solid surface free of vibrations and suited for fastening with Poresta® Profi Flex must be available.
- The shower system is generally accessible for wheel chairs when using tiles of a minimum size of 100 x 100 mm. If glass fabric is worked into the tile adhesive bed, also tiles of a minimum size of 50 x 50 mm may be used.
- Suitable only for use indoor.

### Example for installation with Poresta® UBE substrate element:

Mounting height/finished floor level	100 mm
Poresta® BF 70	-70 mm
2 layers of Poresta® Profi Flex	-10 mm
Poresta® UBE substrate element	= 20 mm

The shower system Poresta® BF 70 meets the requirements relating to the construction materials of construction material class B2 according to DIN 4102-1 (normally inflammable) of class E according to DIN EN 1350-1 in installed condition.

-  The relevant processing guidelines of all trades involved must be observed.
-  1 For the installation (screed base height >75 mm), either substructure elements (not included in the scope of supply) or a cast plaster floor base are being used.
-  2 Apply Poresta® Profi Flex to both sides. If add-on boards are used, apply Poresta® Profi Flex also to the front sides of the BF 70 and to the add-on boards.
-  3 Edge insulation strips shall be provided by the owner.
-  4 Remove sealing ring from the plug-in connection and insert into sleeve.
-  5 After installation of the outlet fitting, a leak test is to be performed.
-  6 Before closing the drain duct apply a suitable thermal and acoustic protective sheathing to the drain line.
-  7 Close the drain duct with Poresta® Profi Flex. The Poresta® Profi Flex should not be too moist after mixing. The processing instructions of the manufacturer shall be observed.
-  8 The processing guidelines of the Poresta® KMK are to be observed.

# Einbauanleitung

## Mounting instruction







## Montagehandleiding

## Instructions de montage

## Istruzioni di montaggio

### Toepassing:

- Het douchesysteem Poresta® BF 70 kan door de monteur afhankelijk van maten, inbouwhoogte en geometrie van het douchesysteem aan de zijanten en tegenover de afvoer variabel worden ingekort.
- Er moet ook rekening worden gehouden met de gebruikswijze van de douche (spatbescherming, bewegingsruimte enz.).
- Voor de montage van het douchesysteem moet een vlakke, schone, draagkrachtige, trilvrije en voor verwerking van de Poresta® Profi Flex geschikte ondergrond aanwezig zijn.
- Het douchesysteem is in principe voor een rolstoel geschikt, als tegels met een minimale grootte van 100 x 100 mm worden toegepast. Bij verwerking van glasvezelmateriaal in de plakondergrond kunnen ook tegels van minimaal 50 x 50 mm worden gebruikt.
- Alleen geschikt voor toepassing in binnenruimte.

-  Met de betreffende toepassingsrichtlijnen van alle betrokken onderdelen moet rekening worden gehouden.
-  **1** Bij inbouw (estrikhoogte >75 mm) moeten onderbouwelementen (niet in levering inbegrepen) of een gegoten estrikondergrond worden toegepast.
-  **2** Poresta® Profi Flex aan beide kanten aanbrengen. Wanneer er aanbouwboards worden gebruikt, moet er ook Poresta® Profi Flex op de kopkanten van de BF 70 en op de aanbouwboards worden aangebracht.
-  **3** Randdichtingsstroken zijn niet in de levering inbegrepen.
-  **4** Dichtingsring van de steekverbinding wegnemen en in de mof plaatsen.
-  **5** Na de installatie van de afvoergarnituur moet de dichtheid worden getest.
-  **6** Vóór afsluiten van het afvoerkanaal een geschikte warmte- en geluidsisolatiemantel aan de afvoerleiding aanbrengen.
-  **7** Het afvoerkanaal met Poresta® Profi Flex afsluiten. Poresta® Profi Flex niet te dun aanroeren. De verwerkingsaanwijzingen van de fabrikant in acht nemen.
-  **8** Met de betreffende toepassingsrichtlijnen van Poresta® KMK moet rekening worden gehouden.

### Montagevoorbeeld met Poresta® UBE onderbouwelement:

Opbouwhoogte/douchebak	100 mm
Poresta® BF 70	-70 mm
2 lagen Poresta® Profi Flex	-10 mm
Poresta® UBE onderbouwelement	= 20 mm

Het douchesysteem Poresta® BF 70 voldoet in ingebouwde toestand aan de eisen voor bouwmaterialen van brandklasse B2 conform DIN 4102-1 (normaal ontvlambaar) van klasse E conform DIN-EN 1350-1.

# Einbauanleitung

## Mounting instruction

## Montagehandleiding

## Instructions de montage

## Istruzioni di montaggio

Poresta® BF 70

### Utilisation:

- Le système de douche Poresta® BF 70 peut être raccourci par l'installateur de manière variable à côté et en face de la conduite d'écoulement, et ceci en tenant compte des dimensions, de la hauteur de montage et de la géométrie du système de douche même.
- Il faut prendre en considération le mode d'utilisation du poste de douche (protection contre la projection de gouttes d'eau, espace de mouvement etc.).
- Pour l'installation du système de douche, il est nécessaire de disposer d'une surface de base plane, propre, capable de porter le système, antivibratoire et appropriée à l'application de la Poresta® Profi Flex.
- En général, le système de douche permet l'accès en fauteuil roulant à la condition de poser des carreaux d'une dimension minimale de 100 x 100 mm. Si le lit de pose des carreaux est renforcé par un tissu de fibres de verre, il est possible d'utiliser également des carreaux d'une dimension minimale de 50 x 50 mm.
- Ne se prête qu'à l'installation à l'intérieur de bâtiments.

 Les instructions correspondantes de mise en oeuvre de tous les métiers participants sont à respecter.

 **1** Lors de l'installation (hauteur de chape >75 mm), il faut utiliser des éléments de support de base (pas compris dans la fourniture) ou un socle coulé de chape.

 **2** Appliquer la Poresta® Profi Flex sur les deux faces. En cas d'utilisation d'éléments d'extension, appliquer la Poresta® Profi Flex également sur les flancs du BF 70 ainsi que sur les tablettes annexées.

 **3** Les bandes de désolidarisation sont à prévoir par le client.

 **4** Enlever le joint du tube et le placer dans le manchon.

 **5** Après installation du tube d'évacuation d'eau, il faut procéder à un contrôle d'étanchéité.

 **6** Avant de fermer le conduit d'écoulement, veiller à envelopper le conduit et l'insonoriser.

 **7** Fermeture du conduit d'écoulement par de la Poresta® Profi Flex. Préparer la colle de manière à obtenir une consistance assez solide. Observer les directives de mise en oeuvre du fabricant.

 **8** Respecter les instructions de mise en oeuvre du Poresta® KMK.

Exemple d'installation avec élément de réhausse Poresta® UBE:

Hauteur de montage/sol fini	100 mm
Poresta® BF 70	-70 mm
2 couches de Poresta® Profi Flex	-10 mm
Élément de réhausse Poresta® UBE	= 20 mm

Le système de douche Poresta® BF 70 répond, à l'état monté, aux exigences sur les matériaux du bâtiment de la catégorie de matériaux B2 conformément à DIN 4102-1 (inflammable normalement) de la catégorie E conformément à DIN EN 1350-1.



# Einbauanleitung

## Mounting instruction

## Montagehandleiding

## Instructions de montage

## Istruzioni di montaggio

Uso:

- Il sistema doccia Poresta® BF 70 può essere accorciato dall'installatore in considerazione della grandezza, dell'altezza d'installazione e della geometria del sistema doccia lateralmente e di fronte allo scarico in modo variabile.
- Si deve prendere in considerazione il modo d'utilizzazione del posto di doccia (protezione contro gli spruzzi di acqua, spazio di movimento ecc.).
- Per l'installazione del sistema doccia deve esistere un sottosuolo piano, pulito, solido, libero di vibrazioni e adatto per l'incollaggio per mezzo del Poresta® Profi Flex.
- Il sistema doccia è generalmente accessibile con sedia a rotelle, se piastrelle di una grandezza minima di 100 x 100 mm sono usate. Ad integrazione di un tessuto di vetro nel letto d'incollaggio piastrelle anche piastrelle di una grandezza minima di 50 x 50 mm possono essere usate.
- Adatto solo per l'uso in locali chiusi.

 Si deve osservare le istruzioni corrispondenti di lavorazione di tutti i mestieri partecipanti.

 **1** All'installazione (altezza del pavimento > 75 mm), si deve utilizzare elementi di supporto di base (non compresi nella fornitura) o uno zoccolo colato di pavimento.

 **2** Applicare Poresta® Profi Flex su entrambi i lati. Se si utilizzano assi di montaggio, Poresta® Profi Flex deve essere applicato anche sui fianchi del BF 70 e sugli assi di montaggio.

 **3** Le fasce isolanti di bordo sono da fornire dal cliente.

 **4** Togliere l'anello di tenuta dal collegamento ad innesto e metterlo nel manicotto.

 **5** Dopo aver installato il gruppo di scarico è necessario eseguire un controllo della tenuta.

 **6** Prima di chiudere il canale di scarico, la condotta di scarico è da munire di un rivestimento termoisolante ed insonorizzante appropriato.

 **7** Chiusura del canale di scarico con Poresta® Profi Flex. Preparare l'adesivo in modo da ottenere una consistenza assai solida. Si devono osservare le istruzioni di lavorazione del fabbricante.

 **8** Si deve osservare le istruzioni di lavorazione del Poresta® KMK.

Esempio d'installazione con elemento di supporto di base Poresta® UBE:

Altezza di montaggio/ pavimento finito	100 mm
Poresta® BF 70	-70 mm
N. 2 strati di Poresta® Profi Flex	-10 mm
Elemento di supporto di base Poresta® UBE	= 20 mm

Il sistema di doccia Poresta® BF 70 adempie alle esigenze per materiali di costruzione della classe di materiali di costruzione B2 secondo DIN 4102-1 (normalmente infiammabile) della classe E secondo DIN EN 1350-1 in stato installato.

# Einbauanleitung Mounting instruction Montagehandleiding Instructions de montage Istruzioni di montaggio

Poresta® BF 70

Empfohlenes Zubehör / Recommended accessories /  
Aanbevolen toebehoren / Accessoires recommandés /  
Accessori raccomandati:



**Poresta® Profi Flex** zementärer Kleber zur Untergrund-  
verklebung / cement adhesive for gluing on ground /  
cementgebonden lijm voor ondergrondverlijming /  
mortier-colle pour collage de supports / adesivo cementizio  
per incollaggio sottofondo



**Poresta® KMK** Abdichtsystem / Sealing system / Afdichtsys-  
teem / Mastic d'étanchéité / Sistema di guarnizione

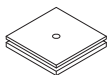

**Poresta® UBE** Unterbauelement / Substrate element /  
Onderbouwelement / Élément de réhausse / Sottostruttre



**Poresta® KMK T** Dichtband / Sealing tape / Afdichtings-  
band / Bande isolante / Fascia isolante



**Poresta® KMK TI** Dichtband-Innenecke / Sealing tape  
interior corner / Afdichtingsband-binnenliggende hoek /  
Bande d'étanchéité pour coin intérieur / Fascia isolante  
per angolo interno

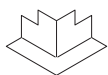

**Poresta® KMK TA** Dichtband-Außenecke / Sealing tape  
exterior corner / Afdichtingsband-buitenliggende hoek /  
Bande d'étanchéité pour coin extérieur / Fascia isolante  
per angolo esterno



Geeigneter Fliesenkleber / Suitable tile adhesive /  
Geschikte tegelplakker / Colle carrelage / Collante per  
piastrelle adatto



Silikon / Silicone / Siliconen / Silicone / Silicone





Weitere Rostdesigns / Further drain cover designs /  
Verdere afvoergarnituur-designs / Autres types de grille

# Einbauanleitung Mounting instruction Montagehandleiding Instructions de montage Istruzioni di montaggio

Poresta® BF 70

 0799	
<p>poresta systems GmbH Illbruckstraße 1 Deutschland 34537 Bad Wildungen</p> <p>13</p> <p>P-BDS-01-2015-03-16</p>	
<p>ETA-13/0386 Bausatz mit Platten zur Abdichtung für Wände und Böden in Nassräumen ETAG 022 Teil 3</p>	
<ul style="list-style-type: none"> <li>- Dicke der Platten</li> <li>- Vorgesehene Nutzungsdauer</li> <li>- Brandverhalten</li> <li>- Wasserdampfdiffusionswiderstandszahl (23°C - 50/93% r.F.)</li> <li>- Wasserdichtheit</li> <li>- Wasserundurchlässigkeit an Plattenfugen</li> <li>- Kratzfestigkeit</li> <li>- Formstabilität</li> <li>- Verschleißfestigkeit</li> <li>- Reinigungsfähigkeit</li> <li>- Reparierbarkeit</li> <li>- Rutschfestigkeit</li> <li>- Verarbeitbarkeit</li> <li>- Rissüberbrückungsfähigkeit</li> <li>- Haftzugfestigkeit</li> <li>- Fugenüberbrückungsfähigkeit</li> <li>- Wasserdichtheit an Durchdringungen</li> <li>- Temperaturbeständigkeit</li> <li>- Wasserbeständigkeit</li> <li>- Alkalibeständigkeit</li> </ul>	<ul style="list-style-type: none"> <li>20 - 120 mm</li> <li>25 Jahre</li> <li>Klasse E</li> <li>sd &gt; 172 m</li> <li>wasserdicht</li> <li>bestanden</li> <li>nach ETAG 022-3</li> <li>nicht relevant</li> <li>alle Richtungen &lt;±1 %</li> <li>nach ETAG 022-3</li> <li>nicht relevant</li> <li>nach ETAG 022-3</li> <li>nicht relevant</li> <li>reparierbar</li> <li>keine Leistung festgestellt</li> <li>verarbeitbar</li> <li>0,4 mm</li> <li>≥ 0,2 MPa ou 0,3 MPa</li> <li>Kat. 0: nicht relevant</li> <li>Kat. 2: wasserdicht</li> <li>temperaturbeständig</li> <li>wasserbeständig</li> <li>alkalibeständig (50°C/8W)</li> </ul>

 0799	
<p>poresta systems GmbH Illbruckstraße 1 Germany 34537 Bad Wildungen</p> <p>13</p> <p>P-BDS-01-2015-03-16</p>	
<p>ETA-13/0386 Watertight covering kit for wet room floors and walls based on watertight boards ETAG 022 part 3</p>	
<ul style="list-style-type: none"> <li>- Thickness of the watertight boards</li> <li>- Assumed intended working life</li> <li>- Reaction to fire</li> <li>- Water vapour diffusion resistance factor (23°C - 50/93% r.h.)</li> <li>- Water tightness</li> <li>- Impermeability at sealings</li> <li>- Scratch resistance</li> <li>- Dimensional stability</li> <li>- Resistance to mechanical wear</li> <li>- Cleanability</li> <li>- Reparability</li> <li>- Slipperiness</li> <li>- Applicability</li> <li>- Crack bridging ability</li> <li>- Bond strength</li> <li>- Joint bridging ability</li> <li>- Water tightness around penetrations</li> <li>- Resistance to temperature</li> <li>- Resistance to water</li> <li>- Resistance to alkalinity</li> </ul>	<ul style="list-style-type: none"> <li>20 - 120 mm</li> <li>25 years</li> <li>class E</li> <li>sd &gt; 172 m</li> <li>watertight</li> <li>passed</li> <li>not relevant acc.</li> <li>ETAG 022-3</li> <li>all directions &lt;±1 %</li> <li>not relevant acc.</li> <li>ETAG 022-3</li> <li>not relevant acc.</li> <li>ETAG 022-3</li> <li>repairable</li> <li>npd</li> <li>applicable</li> <li>0,4 mm</li> <li>≥ 0,2 MPa ou 0,3 MPa</li> <li>Kat. 0: not relevant</li> <li>Kat. 2: watertight</li> <li>temperature resistant</li> <li>water resistant</li> <li>alkali resistant (50°C/8W)</li> </ul>

 0799	
<p>poresta systems GmbH Illbruckstraße 1 Allemagne 34537 Bad Wildungen</p> <p>13</p> <p>P-BDS-01-2015-03-16</p>	
<p>ETA-13/0386 Kit avec panneaux pour l'étanchéité des cloisons et des sols dans les zones humides en intérieur. ETAG 022 part 3</p>	
<ul style="list-style-type: none"> <li>- Épaisseur des plaques</li> <li>- Durée d'usage prévue</li> <li>- Résistance au feu C</li> <li>- Coefficient de résistance à la diffusion de vapeur (23 °C - 50/93 % hum. rel.)</li> <li>- Étanchéité</li> <li>- Imperméabilité des joints</li> <li>- Résistance aux éraflures</li> <li>- Stabilité de la forme</li> <li>- Résistance à l'usure</li> <li>- Aptitude au nettoyage</li> <li>- Réparabilité</li> <li>- Adhérence</li> <li>- Façonnabilité</li> <li>- Capacité de pontage des fissures</li> <li>- Résistance à la traction</li> <li>- Capacité de pontage des joints</li> <li>- Étanchéité autour des intersections</li> <li>- Résistance à la chaleur</li> <li>- Résistance à l'eau</li> <li>- Résistance aux agents alcalins</li> </ul>	<ul style="list-style-type: none"> <li>20 - 120 mm</li> <li>25 ans</li> <li>lasse E</li> <li>sd &gt; 172 m</li> <li>étanche</li> <li>assurée</li> <li>sans objet selon ETAG 022-3</li> <li>&lt;±1 % dans toutes les directions</li> <li>sans objet selon ETAG 022-3</li> <li>sans objet selon ETAG 022-3</li> <li>réparable</li> <li>pas de performance déterminée</li> <li>façonnable</li> <li>0,4 mm</li> <li>≥ 0,2 MPa ou 0,3 MPa</li> <li>cat. 0 : sans objet</li> <li>cat. 2 : étanche</li> <li>assurée</li> <li>assurée</li> <li>assurée (50°C/8W)</li> </ul>