

# AXOR

DE / Gebrauchsanleitung / Montageanleitung	02		
EN / Instructions for use / Assembly instructions	02	AXOR Starck	
FR / Mode d'emploi / Instructions de montage	02	10932XXX	
IT / Istruzioni per l'uso / Istruzioni per Installazione	02		
ES / Modo de empleo / Instrucciones de montaje	03		AXOR Starck
DK / Brugsanvisning / Monteringsvejledning	03		10972XXX
NL / Gebruiksaanwijzing / Handleiding	03		
PT / Instruções para uso / Manual de Instalação	03		
PL / Instrukcja obsługi / Instrukcja montażu	03	AXOR Starck Organic	
SK / Návod na použitie / Montážny návod	04	12731XXX	
CS / Návod k použití / Montážní návod	04		
ZH / 用户手册 / 组装说明	04		AXOR Citterio E
RU / Руководство пользователя / Инструкция по монтажу	05		36772XXX / 36704XXX
SV / Bruksanvisning / Monteringsanvisning	05		
FI / Käyttöohje / Asennusohje	05	AXOR Starck Organic	
LT / Vartotojo instrukcija / Montavimo instrukcijos	05	12771XXX	
HR / Upute za uporabu / Uputstva za instalaciju	06		
RO / Manual de utilizare / Instrucțiuni de montare	06		
HE / הוראות שימוש / הוראות הרכבה	06		
EL / Οδηγίες χρήσης / Οδηγία συναρμολόγησης	06		
SL / Navodilo za uporabo / Navodila za montažo	07		
LV / Lietošanas pamācība / Montāžas instrukcija	07		
ET / Kasutusjuhend / Paigaldusjuhend	07		
SR / Uputstvo za upotrebu / Uputstvo za montažu	07		
NO / Bruksanvisning / Montasjeveiledning	08		
SQ / Udhëzuesi i përdorimit / Udhëzime rreth montimit	08		
BG / Инструкция за употреба / Ръководство за монтаж	08		
AR / دليل الاستخدام / تعليمات التجميع	08		AXOR Citterio E
HU / Használati útmutató / Szerelési útmutató	09		36771XXX / 36704XXX
TR / Kullanım kılavuzu / Montaj kılavuzu	09		
JP / 取扱説明書 / 施工説明書	09		





**△ SICHERHEITSHINWEISE**

- △ Bei der Montage müssen zur Vermeidung von Quetsch- und Schnittverletzungen Handschuhe getragen werden.

**MONTAGEHINWEISE**

- / Vor der Montage muss das Produkt auf Transportschäden untersucht werden. Nach dem Einbau werden keine Transport- oder Oberflächenschäden anerkannt.
- / Die in den Ländern jeweils gültigen Installationsrichtlinien sind einzuhalten.

**SYMBOLERKLÄRUNG**

-  Kein essigsäurehaltiges Silikon verwenden!
-  MASSE (siehe Seite 15)
-  SERVICETEILE (siehe Seite 16)
-  REINIGUNG (siehe Seite 19)
-  PRÜFZEICHEN (siehe Seite 20)

MONTAGE (siehe Seite 10) 





**EN****△ SAFETY NOTES**

- △ Gloves should be worn during installation to prevent crushing and cutting injuries.

**INSTALLATION INSTRUCTIONS**

- / Prior to installation, inspect the product for transport damages. After it has been installed, no transport or surface damage will be honoured.
- / The plumbing codes applicable in the respective countries must be observed.

**SYMBOL DESCRIPTION**

-  Do not use silicone containing acetic acid!
-  DIMENSIONS (see page 15)
-  SPARE PARTS (see page 16)
-  CLEANING (see page 19)
-  TEST CERTIFICATE (see page 20)

ASSEMBLY (see page 10) 





**△ CONSIGNES DE SÉCURITÉ**

- △ Lors du montage, porter des gants de protection pour éviter toute blessure par écrasement ou coupure.

**INSTRUCTIONS POUR LE MONTAGE**

- / Avant son montage, s'assurer que le produit n'a subi aucun dommage pendant le transport. Après le montage, tout dommage de transport ou de surface ne pourra pas être reconnu.
- / Les directives d'installation en vigueur dans le pays concerné doivent être respectées.

**DESCRIPTION DU SYMBOLE**

-  Ne pas utiliser de silicone contenant de l'acide acétique!
-  DIMENSIONS (voir pages 15)
-  PIÈCES DÉTACHÉES (voir pages 16)
-  NETTOYAGE (voir pages 19)
-  CLASSIFICATION ACOUSTIQUE ET DÉBIT (voir pages 20)

MONTAGE (voir pages 10) 





**IT****△ INDICAZIONI SULLA SICUREZZA**

- △ Durante il montaggio, per evitare ferite da schiacciamento e da taglio bisogna indossare guanti protettivi.

**ISTRUZIONI PER IL MONTAGGIO**

- / Prima del montaggio è necessario controllare che non ci siano stati danni durante il trasporto. Una volta eseguito il montaggio, non verranno riconosciuti eventuali danni di trasporto o delle superfici.
- / Vanno rispettate le direttive di installazione nazionali vigenti nel rispettivo paese.

**DESCRIZIONE SIMBOLO**

-  Non utilizzare silicone contenente acido acetico!
-  INGOMBRI (vedi pagg. 15)
-  PARTI DI RICAMBIO (vedi pagg. 16)
-  PULITURA (vedi pagg. 19)
-  SEGNO DI VERIFICA (vedi pagg. 20)

MONTAGGIO (vedi pagg. 10) 





**△ INDICACIONES DE SEGURIDAD**

- △ Durante el montaje deben utilizarse guantes para evitar heridas por aplastamiento o corte.

**INDICACIONES PARA EL MONTAJE**

- / Antes del montaje se debe examinarse el producto contra daños de transporte. Después de la instalación no se reconoce ningún daño de transporte o de superficie.
- / Es obligatorio el cumplimiento de las directrices de instalación vigentes en el país respectivo.

**DESCRIPCIÓN DE SÍMBOLOS**

-  No utilizar silicona que contiene ácido acético!
-  DIMENSIONES (ver página 15)
-  REPUESTOS (ver página 16)
-  LIMPIAR (ver página 19)
-  MARCA DE VERIFICACIÓN (ver página 20)

MONTAJE (ver página 10) 





**DK****△ SIKKERHEDSANVISNINGER**

- △ Ved monteringen skal der bruges handsker for at undgå kvæstelser og snitsår.

**MONTERINGSANVISNINGER**

- / Før monteringen skal produktet kontrolleres for transportskader. Efter monteringen godkendes transportskader eller skader på overfladen ikke længere.
- / Installationsbestemmelserne, der gælder i det enkelte land, skal overholdes.

**SYMBOLBESKRIVELSE**

-  Der må ikke benyttes eddikesyreholdig silikone!
-  MÅLENE (se s. 15)
-  RESERVEDELE (se s. 16)
-  RENGØRING (se s. 19)
-  GODKENDELSE (se s. 20)

MONTERING (se s. 10) 





**△ VEILIGHEIDSIINSTRUCTIES**

- △ Bij de montage moeten ter voorkoming van knel- en snijwonden handschoenen worden gedragen.

**MONTAGE-INSTRUCTIES**

- / Vóór de montage moet het product gecontroleerd worden op transportschade. Na de inbouw wordt geen transport- of oppervlakteschade meer aanvaard.
- / De in de overeenkomstige landen geldende installatie-richtlijnen moeten nageleefd worden.

**SYMBOOLBESCHRIJVING**

-  Gebruik geen zuurhoudende siliconel!
-  MATEN (zie blz. 15)
-  SERVICE ONDERDELEN (zie blz. 16)
-  REINIGEN (zie blz. 19)
-  KEURMERK (zie blz. 20)

MONTAGE (zie blz. 10) 





**PT****△ AVISOS DE SEGURANÇA**

- △ Durante a montagem devem ser utilizadas luvas de protecção, de modo a evitar ferimentos resultantes de entalamentos e de cortes.

**AVISOS DE MONTAGEM**

- / Antes da montagem deve-se controlar o produto relativamente a danos de transporte. Após a montagem não são aceites quaisquer danos de transporte ou de superfície.
- / A prescrições de instalação válidas nos respetivos países devem ser respeitadas.

**DESCRIÇÃO DO SÍMBOLO**

-  Não utilizar silicone que contenha ácido acético!
-  MEDIDAS (ver página 15)
-  PEÇAS DE SUBSTITUIÇÃO (ver página 16)
-  LIMPEZA (ver página 19)
-  MARCA DE CONTROLO (ver página 20)

MONTAGEM (ver página 10) 





## △ WSKAZÓWKI BEZPIECZEŃSTWA

- △ Aby uniknąć zranień na skutek zgniecenia lub przecięcia, podczas montażu należy nosić rękawice ochronne.

## WSKAZÓWKI MONTAŻOWE

- / Przed montażem należy skontrolować produkt pod kątem szkód transportowych. Po montażu nie widać żadnych szkód transportowych ani szkód na powierzchni.
- / Należy przestrzegać wytycznych instalacyjnych obowiązujących w danym kraju.

## OPIS SYMBOLU

-  Nie stosować silikonów zawierających kwas octowy!
-  WYMIARY (patrz strona 15)
-  CZĘŚCI SERWISOWE (patrz strona 16)
-  CZYSZCZENIE (patrz strona 19)
-  ZNAK JAKOŚCI (patrz strona 20)

MONTAŻ (patrz strona 10) 

## SK





### △ BEZPEČNOSTNÉ POKYNY

- △ Pri montáži musíte nosiť rukavice, aby ste predišli pomliaždeninám a rezným poraneniam.

### POKYNY PRE MONTÁŽ

- / Pred montážou musíte produkt skontrolovať, či nebol počas transportu poškodený. Po zabudovaní nebudú uznané žiadne škody spôsobené transportom alebo poškodenia povrchu.
- / Je potrebné dodržiavať smernice o inštalácii, ktoré sú práve teraz platné v krajinách.

## POPIS SYMBOLOV

-  Nepoužívať silikon s obsahom kyseliny octovej!
-  ROZMERY (viď strana 15)
-  SERVISNÉ DIELY (viď strana 16)
-  ČISTENIE (viď strana 19)
-  OSVEDČENIE O SKÚŠKE (viď strana 20)

MONTÁŽ (viď strana 10) 





## △ BEZPEČNOSTNÍ POKYNY

- △ Pro zabránění řezným zraněním a pohmožděninám je nutné při montáži nosit rukavice.

## POKYNY K MONTÁŽI

- / Před montáží je třeba produkt zkontrolovat, zda nebyl při transportu poškozen. Po zabudování nebudou uznány žádné škody způsobené transportem nebo poškození povrchu.
- / Je třeba dodržovat montážní pravidla platná v dané zemi.

## POPIS SYMBOLŮ

-  Nepoužívat silikon s obsahem kyseliny octové!
-  ROZMĚRY (viz strana 15)
-  SERVISNÍ DÍLY (viz strana 16)
-  ČIŠTĚNÍ (viz strana 19)
-  ZKUŠEBNÍ ZNAČKA (viz strana 20)

MONTÁŽ (viz strana 10) 

## ZH





### △ 安全技巧

- △ 装配时为避免挤压和切割受伤，必须戴上手套。

### 安装提示

- / 安装前必须检查产品是否受到运输损害。安装后将不认可运输损害或表面损伤。
- / 请遵守当地国家现行的安装规定。

### 符号说明

-  请勿使用含有乙酸的硅胶！
-  大小 (参见第 15 页)
-  备用零件 (参见第 16 页)
-  清洗 (参见第 19 页)
-  检验标记 (参见第 20 页)

安装 (参见第 10 页) 





## △ УКАЗАНИЯ ПО ТЕХНИКЕ БЕЗОПАСНОСТИ

- △ Во время монтажа следует надеть перчатки во избежание прищемления и порезов.

## УКАЗАНИЯ ПО МОНТАЖУ

- / Перед монтажом следует проверить изделие на предмет повреждений при перевозке. После монтажа претензии о возмещении ущерба за повреждения при перевозке или повреждения поверхностей не принимаются.
- / Необходимо соблюдать требования по монтажу, действующие в соответствующих странах.

## ОПИСАНИЕ СИМВОЛОВ

-  Не применяйте силикон, содержащий уксусную кислоту.
-  РАЗМЕРЫ (см. стр. 15)
-  КОМПЛЕКТ (см. стр. 16)
-  ОЧИСТКА (см. стр. 19)
-  ЗНАК ТЕХНИЧЕСКОГО КОНТРОЛЯ (см. стр. 20)

МОНТАЖ (см. стр. 10)



## SV





### △ SÄKERHETSANVISNINGAR

- △ Handskar ska bäras under monteringsarbetet så att man kan undvika kläm- och skärskador.

### MONTERINGSANVISNINGAR

- / Det måste undersökas om produkten har transportskador innan den monteras. Efter monteringen accepteras inga transport- eller ytskiktsskador.
- / De installationsriktlinjer som gäller i länderna ska följas.

### SYMBOLFÖRKLARING

-  Använd inte silikon som innehåller ättiksyra!
-  MÅTTEN (se sidan 15)
-  RESERVDLAR (se sidan 16)
-  RENGÖRING (se sidan 19)
-  TESTSIGILL (se sidan 20)

MONTERING (se sidan 10)







## △ TURVALLISUUSOHJEET

- △ Asennuksessa on käytettävä käsiineitä puristumien ja viiltojen aiheuttamien tapaturmien estämiseksi.

## ASENNUSOHJEET

- / Ennen asennusta on tarkastettava tuotteen mahdolliset kuljetusvahingot. Asennuksen jälkeen kuljetus- ja pintavaurioita ei hyväksytä.
- / Jokaisessa maassa on noudatettava siellä päteviä asennusohjeita.

## MERKIN KUVAUS

-  Älä käytä etikkahappopitoista silikonial!
-  MITAT (katso sivu 15)
-  VARAOSAT (katso sivu 16)
-  PUHDISTUS (katso sivu 19)
-  KOESTUSMERKKI (katso sivu 20)

ASENNUS (katso sivu 10)



## LT





### △ SAUGUMO TECHNIKOS NURODYMAI

- △ Apsaugai nuo užspaudimo ir įsijovimo montavimo metu mūvėkite pirštines.

### MONTAVIMO INSTRUKCIJA

- / Prieš montuojant būtina patikrinti, ar gaminyje nebuvo pažeistas transportavimo metu. Sumontavus pretenzijos dėl transportavimo ir paviršiaus pažeidimų nepriimamos.
- / Laikykitės atitinkamoje šalyje galiojančių direktyvų dėl įrengimo.

### SIMBOLIO APRAŠYMAS

-  Nenaudokite silikono, kurio sudėtyje yra acto rūgšties!
-  IŠMATAVIMAI (žr. psl. 15)
-  ATSARGINĖS DALYS (žr. psl. 16)
-  VALYMAS (žr. psl. 19)
-  BANDYMO PAŽYMA (žr. psl. 20)

MONTAVIMAS (žr. psl. 10)



## △ SIGURNOSNE UPUTE

△ Prilikom montaže se radi sprječavanja prignječenja i posjekotina moraju nositi rukavice.

## UPUTE ZA MONTAŽU

- / Prije montaže mora se provjeriti je li proizvod oštećen prilikom transporta. Nakon ugradnje se ne priznaju nikakve reklamacije koje se odnose na površinska i transportna oštećenja.
- / Obvezno se moraju uvažiti propisi o instalacijama koji vrijede u dotičnoj zemlji.

## OPIS SIMBOLA

 Nemojte koristiti silikon koji sadrži octenu kiselinu!

 MJERE (pogledaj stranicu 15)

 REZERVNI DJELOVI (pogledaj stranicu 16)

 ČIŠĆENJE (pogledaj stranicu 19)

 OZNAKA TESTIRANJA (pogledaj stranicu 20)

SASTAVLJANJE (pogledaj stranicu 10) 

## RO

### △ INSTRUȚIUNI DE SIGURANȚĂ

△ La montare utilizați mănuși pentru evitarea contuziunilor și tăierii mâinilor.

### INSTRUȚIUNI DE MONTARE

- / Înainte de instalare verificați, dacă produsul prezintă deteriorări de transport. După instalare garanția nu acoperă deteriorările de transport și cele de suprafață.
- / Respectați reglementările referitoare la instalare valabile în țara respectivă.

### DESCRIEREA SIMBOLURILOR

 Nu utilizați silicon cu conținut de acid acetic!

 DIMENSIUNI (vezi pag. 15)

 PIESE DE SCHIMB (vezi pag. 16)

 CURĂȚARE (vezi pag. 19)

 CERTIFICAT DE TESTARE (vezi pag. 20)

MONTARE (vezi pag. 10) 

## △ הערות בטיחות

△ יש להשתמש בכפפות בזמן ההתקנה כדי למנוע פציעות ונחיתים

## הוראות התקנה

/ לפני ההתקנה, בדוק אם נגרמו למוצר נזקים בהובלה / אחרי ההתקנה, לא נכיר בנזקים שנגרמו בהובלה או בנזקים במשטחים

/ צריך לפעול על פי חוקי השרברבות הישימים במדינת ההתקנה

## תיאור הסמל

אסור להשתמש בסיליקון המכיל חומצה אצטית!  **מידות** (ראה עמוד 15)

**חלקי חילוף** (ראה עמוד 16) 

**ניקוי** (ראה עמוד 19) 

**תעודת בדיקה** (ראה עמוד 20) 

**הרכבה** (ראה עמוד 10) 

## EL

### △ ΥΠΟΔΕΙΞΕΙΣ ΑΣΦΑΛΕΙΑΣ

△ Για να αποφύγετε τραυματισμούς κατά τη συναρμολόγησή πρέπει να φοράτε γάντια.

### ΟΔΗΓΙΕΣ ΣΥΝΑΡΜΟΛΟΓΗΣΗΣ

/ Πριν τη συναρμολόγηση πρέπει να εξεταστεί το προϊόν για ζημιές μεταφοράς. Μετά την εγκατάσταση δεν αναγνωρίζονται ζημιές από τη μεταφορά ή επιφανειακές ζημιές.

/ Θα πρέπει να τηρούνται οι οδηγίες εγκατάστασης που ισχύουν σε κάθε κράτος.

### ΠΕΡΙΓΡΑΦΗ ΣΥΜΒΟΛΩΝ

 Μην χρησιμοποιείτε σιλικόνη που περιέχει οξικό οξύ!

 ΔΙΑΣΤΑΣΕΙΣ (βλ. Σελίδα 15)

 ΑΝΤΑΛΛΑΚΤΙΚΑ (βλ. Σελίδα 16)

 ΚΑΘΑΡΙΣΜΟΣ (βλ. Σελίδα 19)

 ΣΗΜΑ ΕΛΕΓΧΟΥ (βλ. Σελίδα 20)

ΣΥΝΑΡΜΟΛΟΓΗΣΗ (βλ. Σελίδα 10) 





## △ VARNOSTNA OPOZORILA

- △ Pri montaži je treba nositi rokavice, da se preprečijo poškodbe zaradi zmečkanja ali urezov.

## NAVODILA ZA MONTAŽO

- / Pred montažo je treba izdelek preveriti glede morebitnih transportnih poškodb. Po vgradnji transportne ali površinske poškodbe ne bodo več priznane.
- / Upoštevaty je treba pravilnike o inštalacijah, ki veljajo v posamezni državi.

## OPIS SIMBOLA

-  Ne smete uporabiti silikona, ki vsebuje ocatno kislino!
-  MERE (glejte stran 15)
-  REZERVNI DELI (glejte stran 16)
-  ČIŠČENJE (glejte stran 19)
-  PRESKUSNI ZNAK (glejte stran 20)

## MONTAŽA (glejte stran 10)





## △ DROŠĪBAS NORĀDES

- △ Montāžas laikā, lai izvairĪtos no saspiedumiem un iegriezumiem, nepieciešams nēsāt cimdus.

## NORĀDĪJUMI MONTĀŽAI

- / Pirms montāžas nepieciešams pārbaudīt, vai produktam transportēšanas laikā nav radušies bojājumi. Pēc iebūvēšanas bojājumi, kas radušies transportēšanas laikā, vai virsmas bojājumi netiek atzīti.
- / Jāievēro attiecīgās valsts spēkā esošās montāžas prasības.

## SIMBOLU NOZĪME

-  Neizmantot silikonu, kas satur etiķskābi!
-  IZMĒRUS (skat. lpp. 15)
-  REZERVES DAĻAS (skat. lpp. 16)
-  TĪRĪŠANA (skat. lpp. 19)
-  PĀRBAUDES ZĪME (skat. lpp. 20)

## MONTĀŽA (skat. lpp. 10)





## △ OHUTUSJUHISED

- △ Kandke paigaldamisel muljumis- ja lõikevigastuste vältimiseks kindaid.

## PAIGALDAMISJUHISED

- / Enne paigaldamist tuleb toodet kontrollida transportidkajhustuste osas Põrast paigaldamist ei tunnustata enam transporti- või pinnakahjustuste kaebuseid.
- / Vastavas riigis kehtivaid paigalduseeskirju tuleb järgida.

## SÜMBOLITE KIRJELDUS

-  Ärge kasutage äädikhapet sisaldavat silikoonil
-  MÕÕTUDE (vt lk 15)
-  VARUOSAD (vt lk 16)
-  PUHASTAMINE (vt lk 19)
-  KONTROLLSERTIFIKAAT (vt lk 20)

## PAIGALDAMINE (vt lk 10)





## △ SIGURNOSNE NAPOMENE

- △ Prilikom montaže se radi sprečavanja prignječenja i posekatina moraju nositi rukavice.

## INSTRUKCIJE ZA MONTAŽU

- / Pre montaže se mora proveriti da li je proizvod oštećen pri transportu. Nakon ugradnje se ne priznaju nikakve reklamacije koje se odnose na površinska i transportna oštećenja.
- / Treba se pridržavati propisa koji u određenim zemljama važe za instalacije.

## OPIS SIMBOLA

-  Nemojte koristiti silikon koji sadrži sirčetnu kiselinu!
-  MERE (vidi stranu 15)
-  REZERVNI DELOVI (vidi stranu 16)
-  ČIŠČENJE (vidi stranu 19)
-  ISPITNI ZNAK (vidi stranu 20)

## MONTAŽA (vidi stranu 10)





## △ SIKKERHETSHENVISNINGER

- △ Bruk hansker under montasjen for å unngå klem- og kuttskader.

## MONTAGEHENVISNINGER

- / Før montasjen skal produktet sjekkes for transportskader. Etter monteringen aksepteres ikke noen transport- eller overflateskader.
- / Gjeldende retningslinjer for rørløggerarbeid i de enkelte land skal følges.

## SYMBOLBESKRIVELSE

-  Ikke bruk silikon som inneholder eddiksyre!
-  MÅL (se side 15)
-  SERVICEDELER (se side 16)
-  RENGJØRING (se side 19)
-  PRØVEMERKE (se side 20)

## MONTASJE (se side 10)

## SQ





### △ UDHËZIME SIGURIE

- △ Për të evituar lëndimet e pickimeve ose të prerjeve gatë procesit të montimit duhet që të vishni doreza.

### UDHËZIME PËR MONTIMIN

- / Përpara montimit duhet që produkti të kontrollohet për dëmtime nga transporti. Pas instalimit nuk do të njihet asnjë dëmtim nga transporti ose dëmtim i sipërfaqes.
- / Duhet të respektohen linjat udhëzuese të instalimit, të vlefshme për vendet respektive.

### PËRSHKRIMI I SIMBOLIT

-  Mos përdorni silikon që në përbërje ka acid acetik.
-  PËRMASAT (shih faqen 15)
-  PJESËT E SERVISIT (shih faqen 16)
-  PASTRIMI (shih faqen 19)
-  SHENJA E KONTROLLIT (shih faqen 20)

## MONTIMI (shih faqen 10)





## △ УКАЗАНИЯ ЗА БЕЗОПАСНОСТ

- △ При монтажа трябва да се носят ръкавици, за да се избегнат наранявания поради притискане или порязване.

## УКАЗАНИЯ ЗА МОНТАЖ

- / Преди монтажа продуктът трябва да се провери за транспортни щети. След монтажа не се признават транспортни или повърхностни щети.
- / Трябва да бъдат спазвани валидните в съответните страни предписания за инсталиране.

## ОПИСАНИЕ НА СИМВОЛИТЕ

-  Не използвайте silikon, съдържащ оцетна киселина!
-  РАЗМЕРИ (вижте стр. 15)
-  СЕРВИЗНИ ЧАСТИ (вижте стр. 16)
-  ПОЧИСТВАНЕ (вижте стр. 19)
-  КОНТРОЛЕН ЗНАК (вижте стр. 20)

## МОНТАЖ (вижте стр. 10)

## AR





### △ تنبيهات الأمان

- △ يجب ارتداء قفازات لليد أثناء التركيب لتجنب حدوث أضرار الإنحشار أو الجروح

### تعليمات التركيب

- / قبل القيام بعملية التركيب، يجب فحص المنتج للتأكد من خلوه من أية تلفيات ناتجة عن النقل بعد القيام بعملية التركيب، لأن يتم الاعتراف بوجود أية تلفيات سطحية أو تلفيات ناتجة عن عملية النقل.
- / يجب مراعاة القواعد الخاصة بالتركيب وأعمال السباكة وفقاً للوائح الخاصة بكل بلد.

### وصف الرمز

- هام! لا تستخدم السليكون الذي يحتوي على أحماض! 
- أبعاد (راجع صفحة 15) 
- قطع الغيار (راجع صفحة 16) 
- التنظيف (راجع صفحة 19) 
- شهادة اختبار (راجع صفحة 20) 

## التركيب (راجع صفحة 10)







**△ BIZTONSÁGI UTASÍTÁSOK**

- △ A szerelésnél a zúzódások és vágási sérülések elkerülése érdekében kesztyűt kell viselni.

**SZERELÉSI UTASÍTÁSOK**

- / A szerelés előtt ellenőrizni kell, hogy a terméknek nincs-e szállítási sérülése. Beépítés után a szállítási- vagy felületi sérüléseket nem ismerik el.
- / Az egyes országokban érvényes installációs irányelveket be kell tartani.

**SZIMBÓLUMOK LEÍRÁSA**

-  Ne használjon ecetsavtartalmú szilikon!
-  MÉRLETET (lásd a oldalon 15)
-  TARTOZÉKOK (lásd a oldalon 16)
-  TISZTÍTÁS (lásd a oldalon 19)
-  VIZSGAJEL (lásd a oldalon 20)

SZERELÉS (lásd a oldalon 10) 





**TR****△ GÜVENLİK UYARILARI**

- △ Montaj esnasında ezilme ve kesilme gibi yaralanmaları önlemek için eldiven kullanılmalıdır.

**MONTAJ AÇIKLAMALARI**

- / Montaj işleminden önce ürün nakliye hasarları yönünden kontrol edilmelidir. Montaj işleminden sonra nakliye veya yüzey hasarları için sorumluluk üstlenilmemektedir.
- / Ülkelerde geçerli kurum yönetmeliklerine riayet edilmelidir.

**SİMGE AÇIKLAMASI**

-  Asetik asit içeren silikon kullanmayın!
-  ÖLÇÜLERİ (bakınız sayfa 15)
-  YEDEK PARÇALAR (bakınız sayfa 16)
-  TEMİZLEME (bakınız sayfa 19)
-  KONTROL İŞARETİ (bakınız sayfa 20)

**GARANTI BELGESİ****ÜRETİCİ VEYA İTHALATÇI FIRMANIN**

Unvanı: Hansgrohe Armatür Ltd. Şti  
Adresi: Fulya Mahallesi Bahçeler Sokak Efe han 20/C  
Mecidiyeköy Şişli İstanbul

MONTAJI (bakınız sayfa 10) 





**△ 安全上の注意**

- △ 施工の際は手を挟んだり怪我をしないように、手袋をはめてください。

**施工上の注意**

- / 製品の施工前に輸送でのダメージがないか確認してください。施工後のキズ等のお申し出はお断りさせていただきます。
- / 施工行方地域に適用される関連法規をお守りください。

**アイコンの説明**

-  酢酸系シリコンをご使用にならないでください!
-  寸法 (次のページを参照 15)
-  スペアパーツ (次のページを参照 16)
-  お手入れ方法 (次のページを参照 19)
-  認証について (次のページを参照 20)

施工方法 (次のページを参照 10) 

Telefonu:

(0-212) 273 07 30

Faks:

(0-212) 273 07 40

web adresi:

www.hansgrohe.com.tr

**MALIN**

Markası:

Hansgrohe

Cinsi:

Sihhi tesisat malzemesi

Garanti Süresi:

2 YIL

Azami Tamir Süresi:

20 İş günü

GENEL MÜDÜR  
ALBERT EMLEK



Satıcı Firmanın:

Unvanı:

Adresi:

Telefonu:

Faks:

e-posta:

Fatura Tarih ve Sayısı:

Marka ve Modeli:

Teslim Tarihi ve Yeri:

Yetkilinin İmzası:

Firmanın Kaşesi:

BU BÖLÜMÜ, ÜRÜNÜ ALDIĞINIZ  
YETKİLİ SATICI İMZALAYACAK VE  
KAŞELEYECEKTİR.

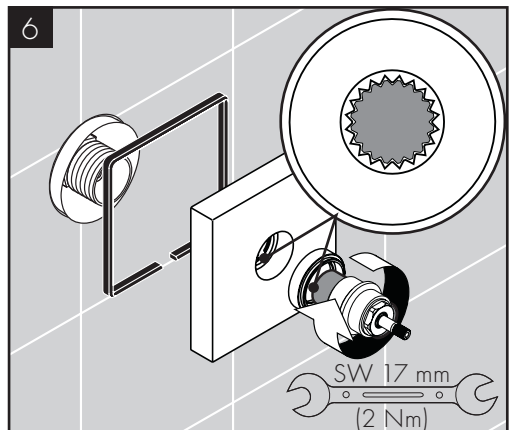
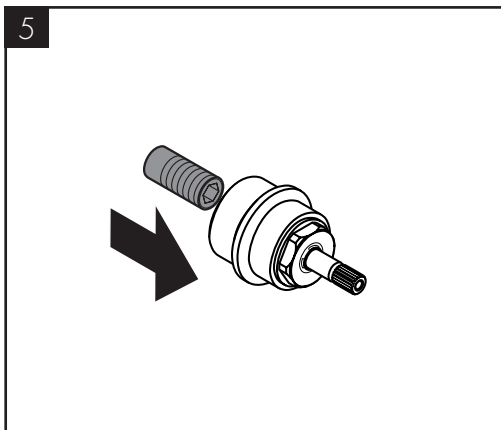
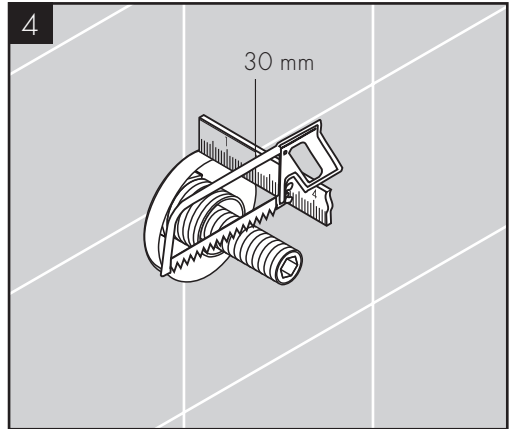
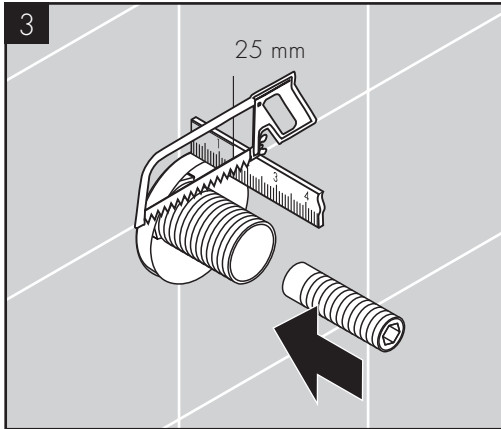
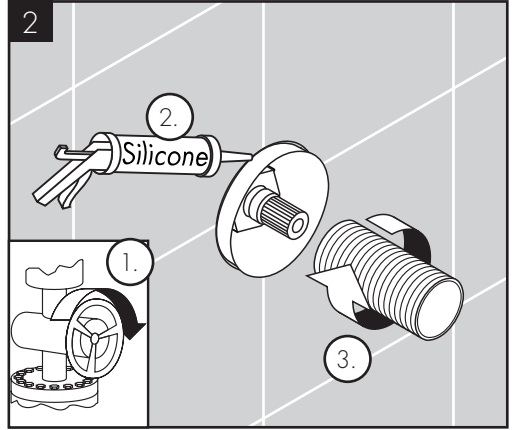
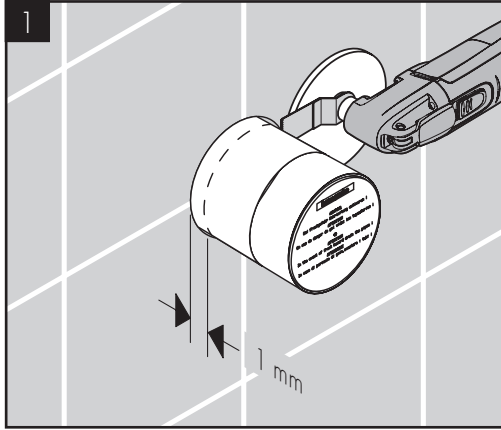

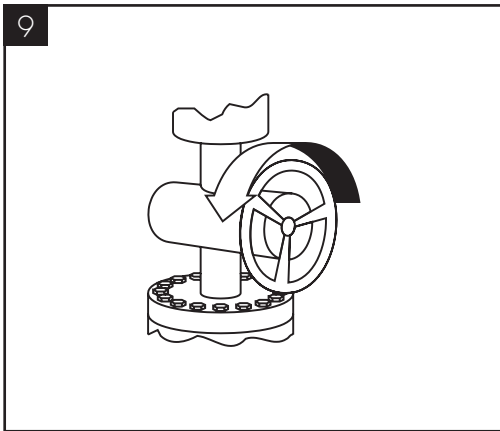
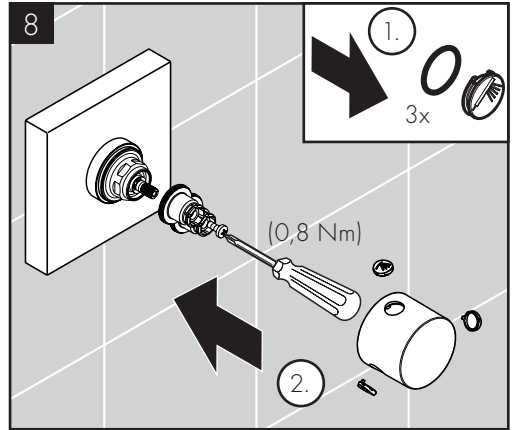
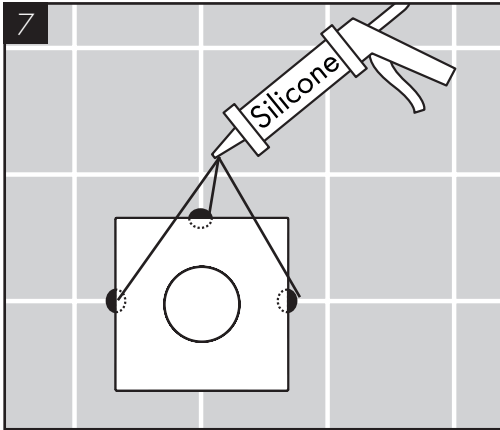

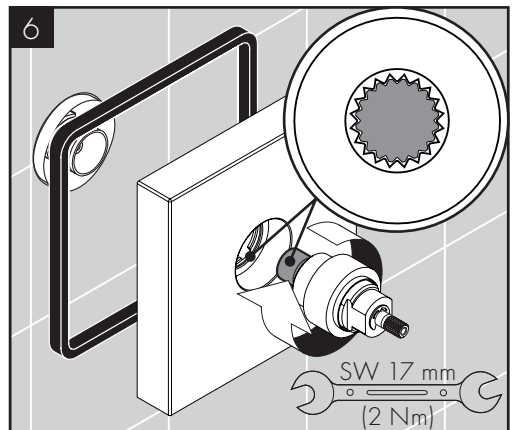
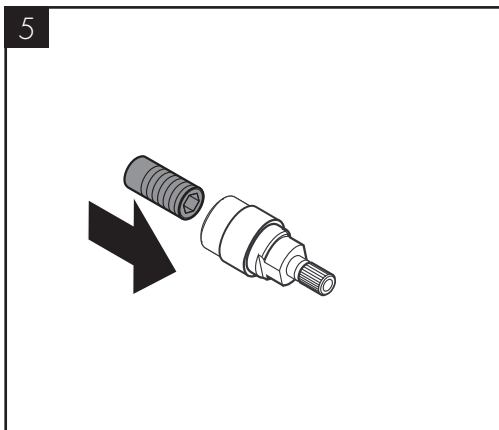
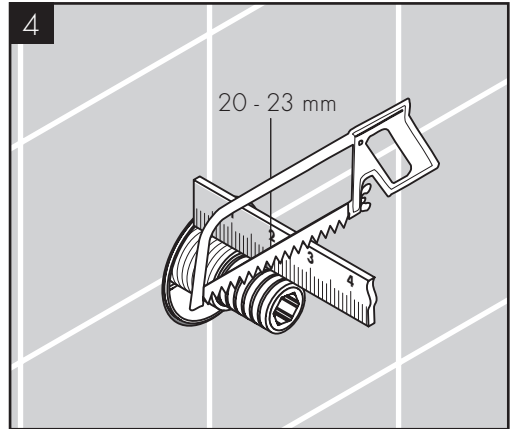
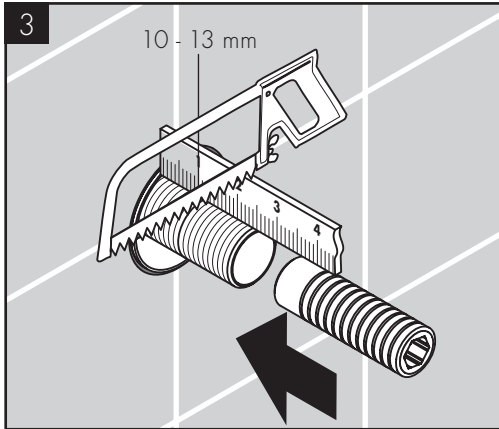
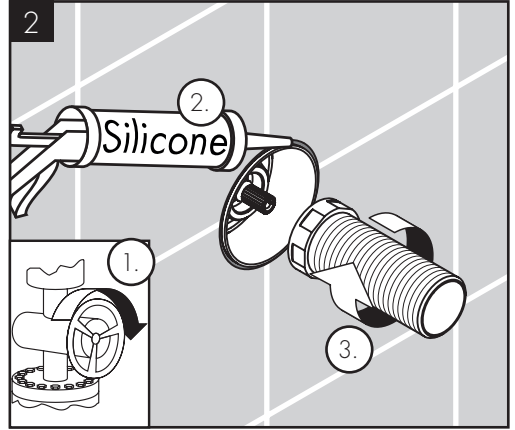
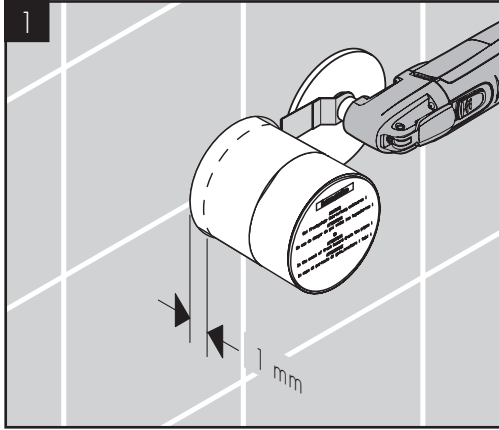

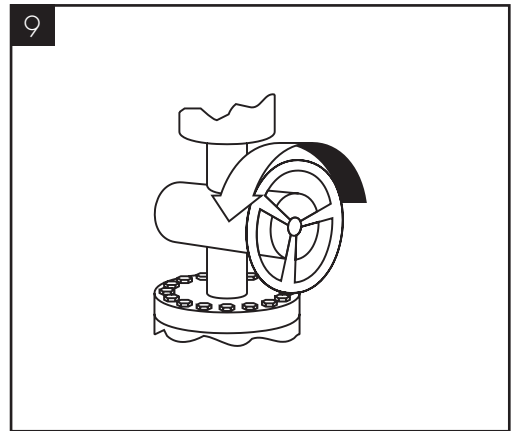
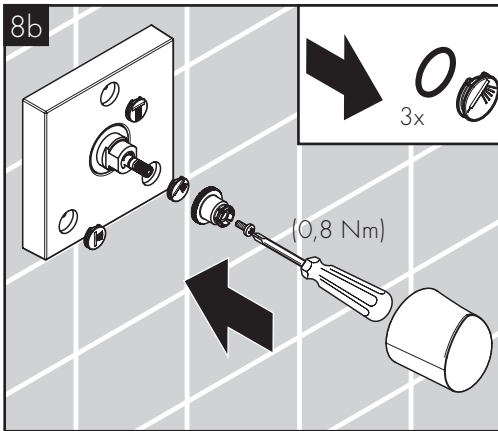
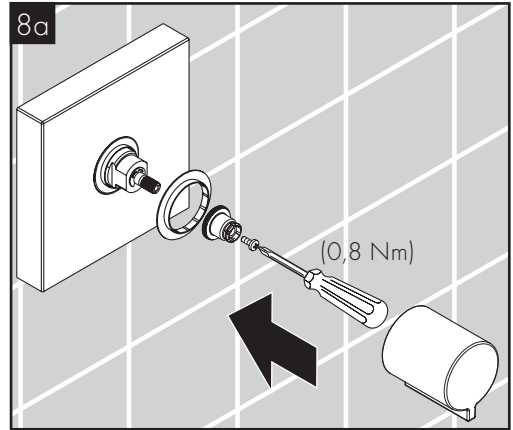
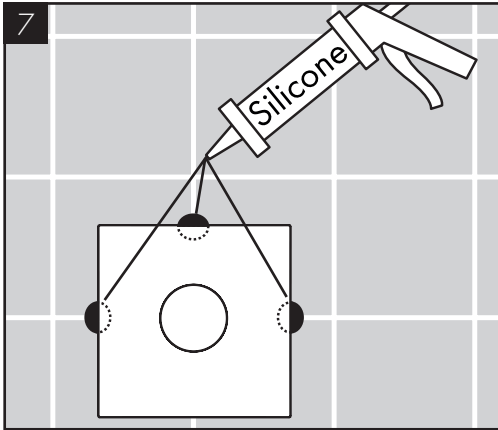

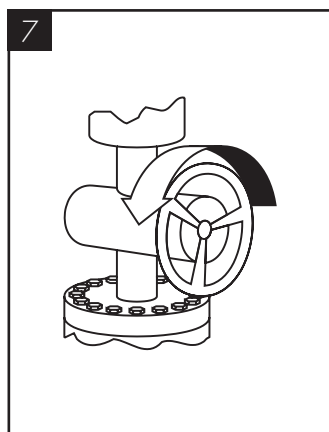
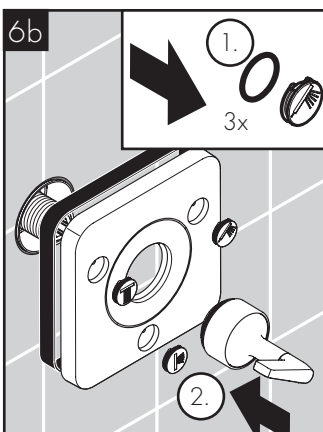
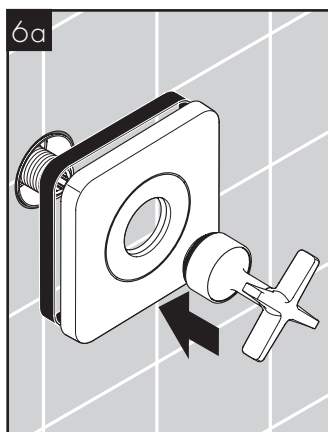
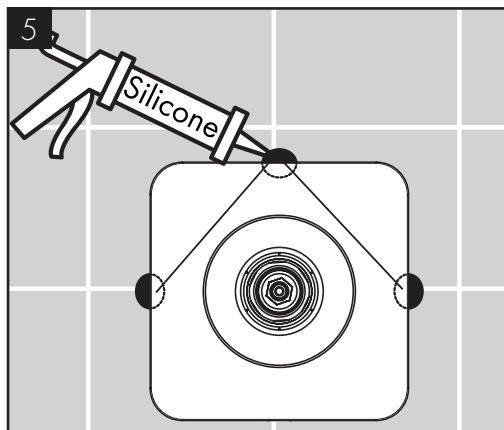
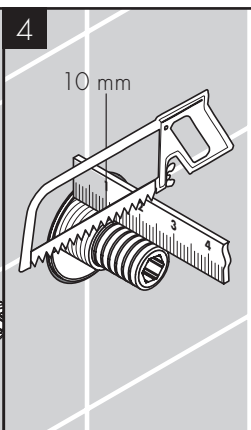
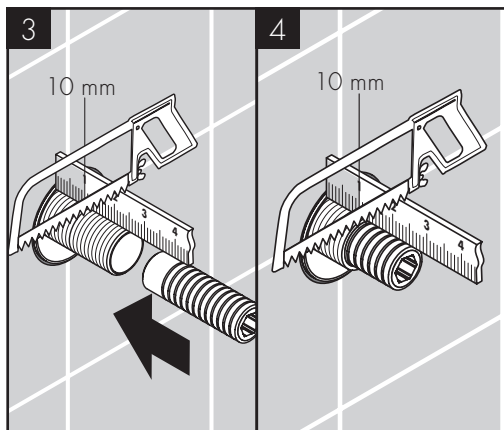
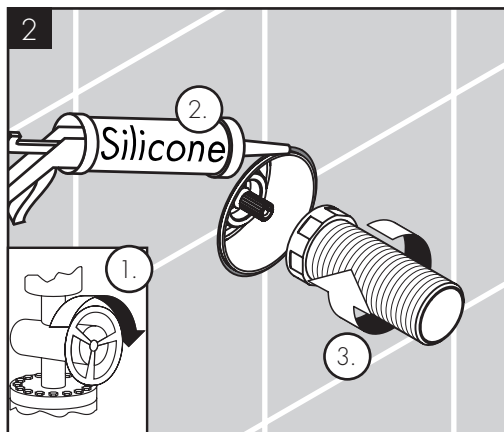
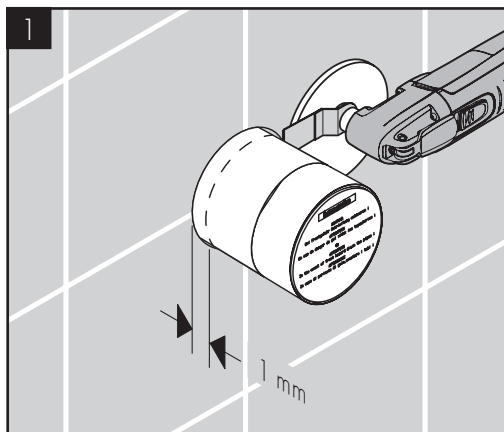



AXOR Starck  
10932XXX

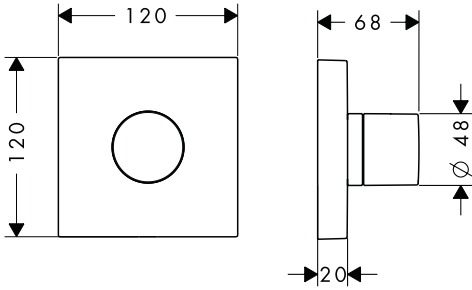

AXOR Starck  
10972XXX

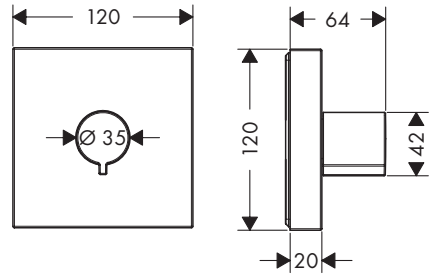

AXOR Starck Organic  
12731XXX / 12771XXX

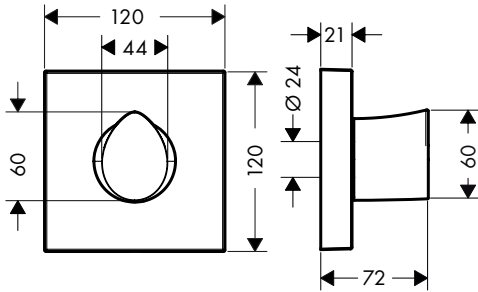

AXOR Citterio E  
36771XXX / 36704XXX

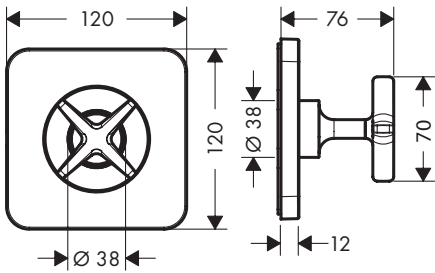

AXOR Citterio E  
36772XXX / 36704XXX

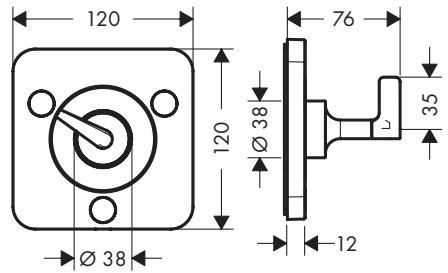



XXX = Farbcodierung / Couleurs / Colors / Trattamento / Acabados / Kleuren / Overflade / Acabamentos /  
 Kody kolorów / Kód povrchové úpravy / Farebné označenie / 颜色代码 / Цветная кодировка / Värikoodaus /  
 Färgkodning / Spalvos / Boje / Coduri de culori / Χρώματα / Barve / Värvid / Krāsu kodi / Označe boja /  
 Fargekode / Цветово кодирание / 仕上げ色 / Kodimi me anë të ngjyrave / الألوان / Renkler / Színkódolás /  
**צבעים**

000 = Chrome

020 = Polished Chrome

130 = Polished Bronze

140 = Brushed Bronze

250 = Brushed Gold-Optic

260 = Brushed Chrome

300 = Polished Redgold

310 = Brushed Redgold

330 = Polished Black Chrome

340 = Brushed Black Chrome

670 = Matt Black

800 = Stainless Steel Optic

820 = Brushed Nickel

950 = Brushed Brass

990 = Polished Gold-Optic

AXOR Citterio E  
 36772XXX / 36704XXX

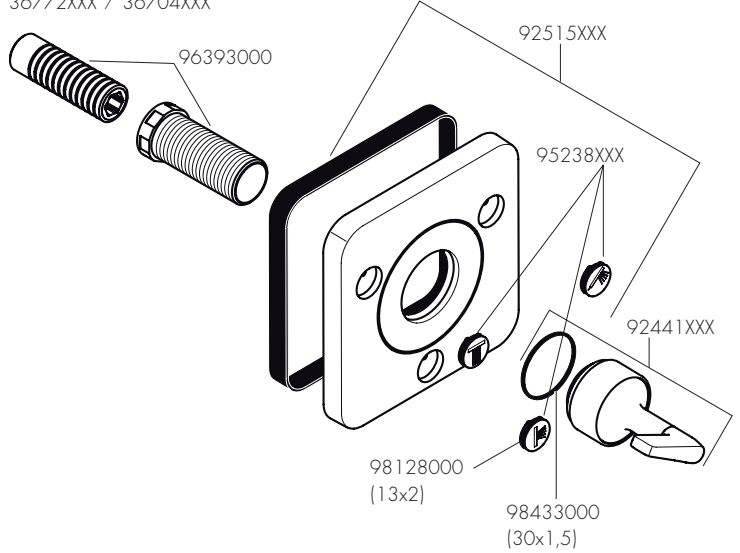

AXOR Citterio E  
 36771XXX / 36704XXX

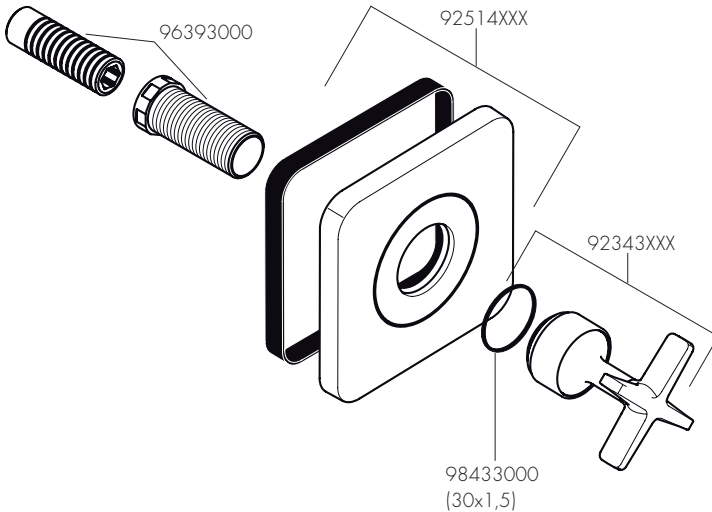





AXOR Starck Organic  
12731XXX

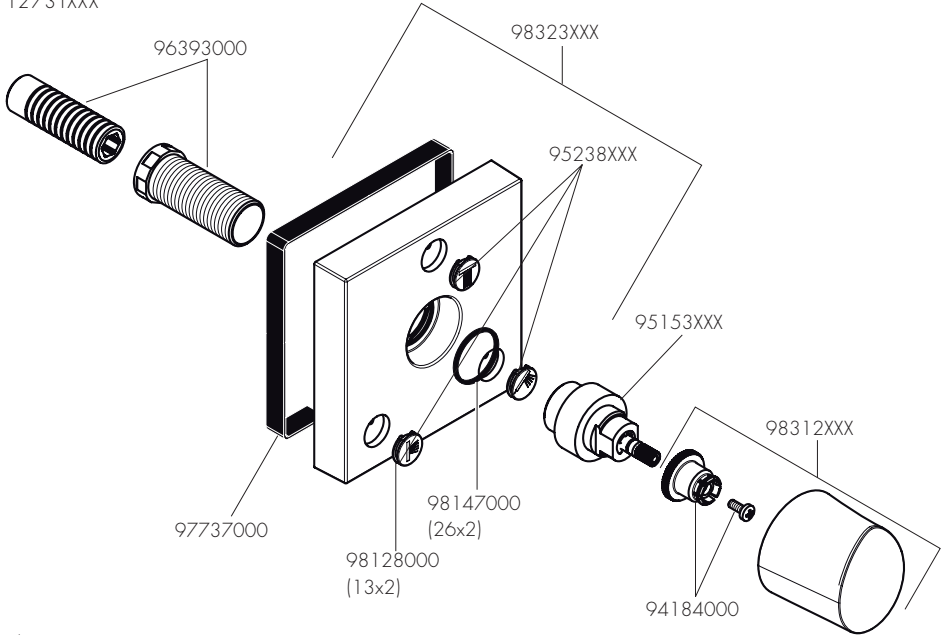

AXOR Starck Organic  
12771XXX

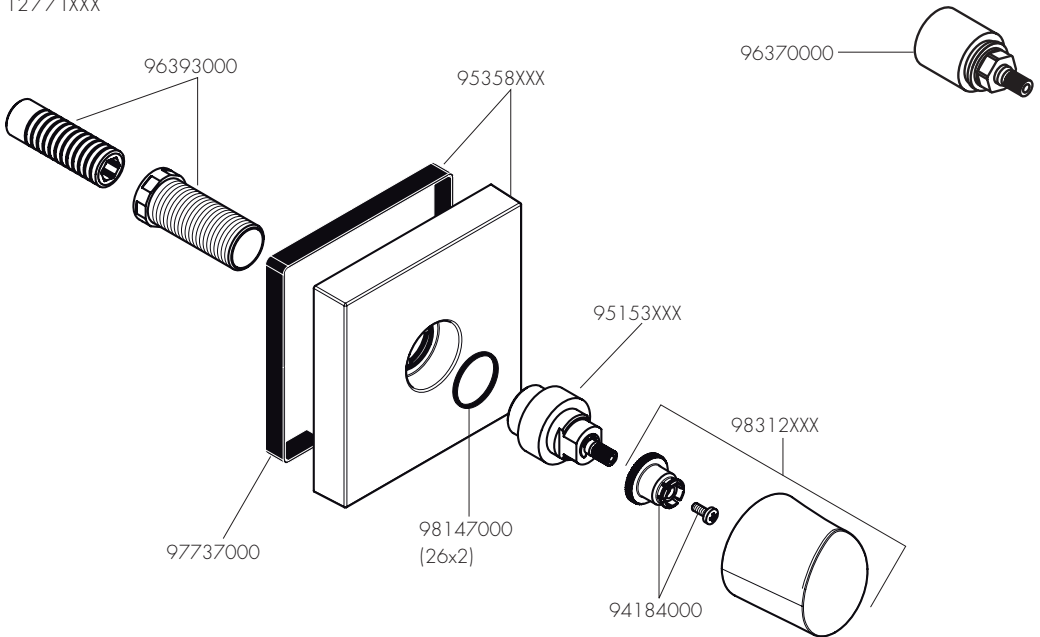



AXOR Starck  
10932XXX

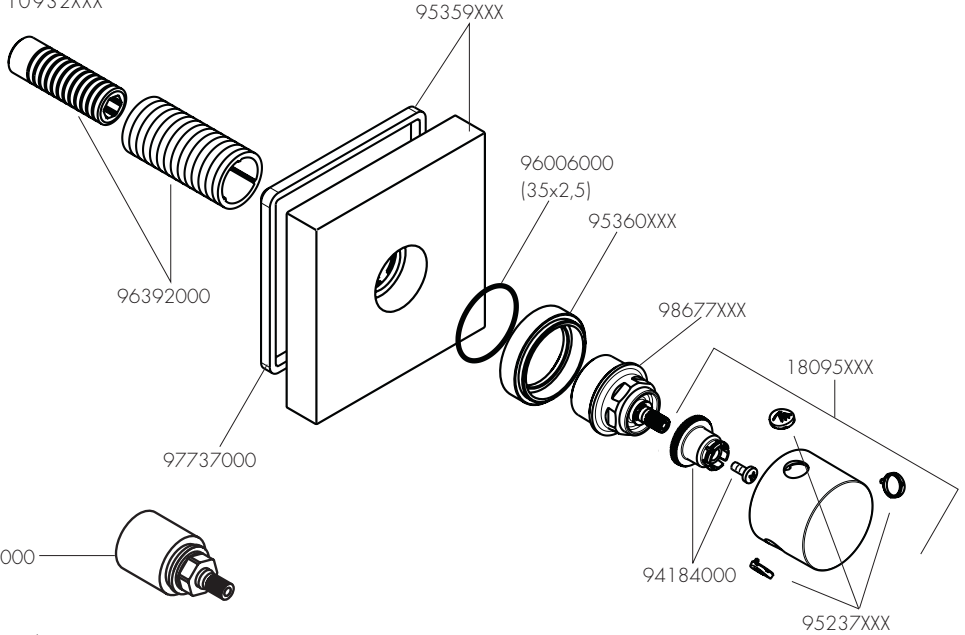

AXOR Starck  
10972XXX

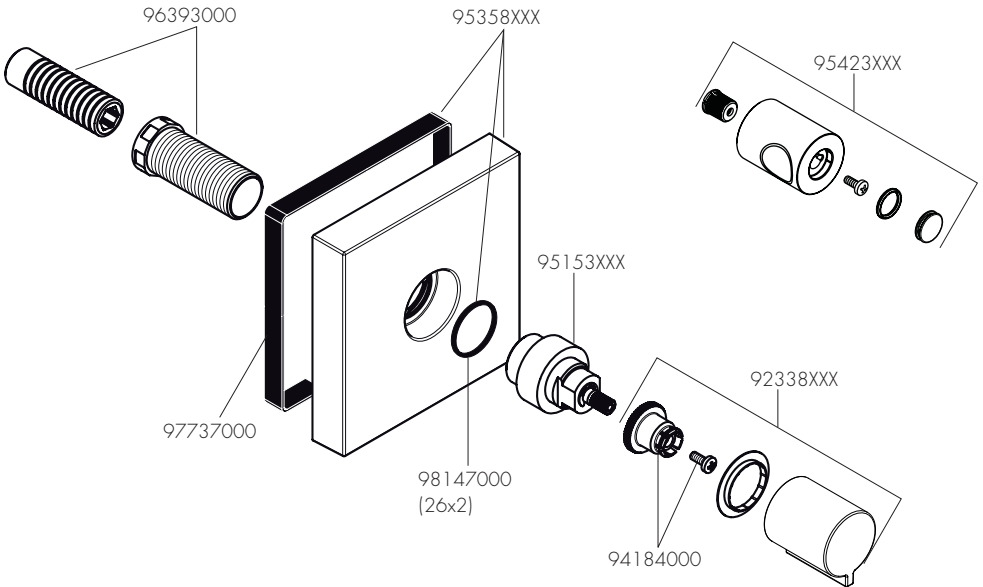



[www.axor-design.com/cleaning-recommendation](http://www.axor-design.com/cleaning-recommendation)

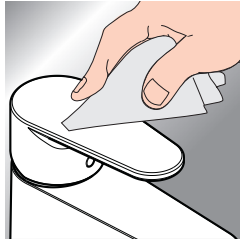
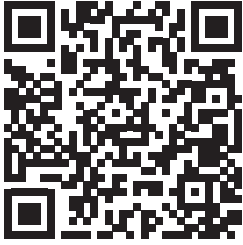

DE / Reinigungsempfehlung / Garantie / Kontakt  
 FR / Recommendation pour le nettoyage / Garanties / Contact  
 EN / Cleaning recommendation / Warranty / Contact  
 IT / Raccomandazione di pulizia / Garanzia / Contatto  
 ES / Recomendaciones para la limpieza / Garantía / Contacto  
 NL / Aanbevelingen inzake reiniging / Garantie / Contact  
 DK / Rengøringsvejledning / Garanti / Kontakt  
 PT / Recomendações de limpeza / Garantia / Contacto  
 PL / Zalecenie dotyczące pielęgnacji / Gwarancja / Kontakt  
 CS / Doporučení k čištění / Záruka / Kontakt  
 SK / Odporúčania pre čistenie / Záruka / Kontakt  
 ZH / 清洁指南 / 担保 / 接触  
 RU / Рекомендации по очистке / Гарантия / Контакты  
 FI / Puhdistussuositus / Takuu / Kosketus  
 SV / Rengöringsrekommendationer / Garanti / Contacto  
 LT / Valymo rekomendacijos / Garantija / Kontaktai

HR / Preporuke za čišćenje / Garancija / Kontakt  
 RO / Recomandări pentru curățare / Garanție / Contact  
 EL / Σύσταση καθαρισμού / Εγγύηση / επαφή  
 SL / Priporočilo za čiščenje / Garancija / Kontakt  
 ET / Puhastussoovitused / Garanti / Kontakt  
 LV / Tīrīšanas ieteikumi / Garantija / Kontakti  
 SR / Preporuke za čišćenje / Garancija / Kontakt  
 NO / Anbefaling for rengjøring / Garanti / Kontakt  
 BG / Препоръка за почистване / Гаранция / Контакт  
 JP / お手入れの方法 / 保証について / ご連絡先  
 SQ / Këshilla rreth pastrimit / Garancia / Kontakt  
 AR / توصيات التنظيف / الضمان / اتصال  
 TR / Temizleme önerisi / Garanti / Temas  
 HU / Tisztítási tanácsok / Garancia / érintkezés  
 HE / המלצות לניקוי / אחריות / איש קשר

# AXOR

P-IX

DVGW

SINTEF

NF



GODKENDT  
TIL DRIKKEVAND

10932XXX	P-IX 29473/II	X
10972XXX	P-IX 29470/II	X
12731XXX		X
12771XXX	P-IX 29470/II	X
36704XXX		X
36771XXX	P-IX 29470/II	X
36772XXX	P-IX 29473/II	X

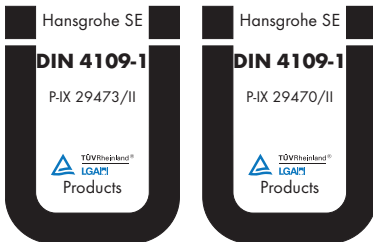

AXOR / Hansgrohe SE

Austraße 5-9

77761 Schiltach

Deutschland

[info@axor-design.com](mailto:info@axor-design.com)

[axor-design.com](http://axor-design.com)

10/2022  
9,04820,06