

Product: **KLUDI SCOPE single lever sink mixer bayonette DN 15**

Ref.: **33938..75**

Product description

single lever sink mixer bayonette DN 15
 solid lever
 single hole mounted
 flow class A
 Cache aerator M 16,5 x l
 ceramic cartridge with hot water safety device
 swivelling (360°) spout
 for installation below the window
 remaining height at the base: 25 mm
 shank-fixing
 flexible high pressure supply tubes G 3/8
 noise group I
 certification mark submitted

Finishes:
 05 chrome
 96 stainless steel look

Advertisement

- * KLUDI GmbH & Co KG SCOPE single lever sink mixer bayonette DN 15 item no. 33938..75
- ** ceramic cartridge with hot water safety device Ø 35 mm, DIN EN 817
- *** brass, DIN 50930-6

single lever sink mixer bayonette, manufacturer KLUDI GmbH & Co KG KLUDI SCOPE single lever sink mixer bayonette item no. 33938..75, DN 15, surface: 05 = chrome plated brass, 96 = stainless steel look, type: single lever sink mixer bayonette DN 15, swivel (range 360°) spout, solid lever, lever projection 92 mm, Cache aerator M 16,5 x l, noise level DIN 4109 group I, report no. P- IX ... / IA, flow class A (max. 0,25 l/s), nozzle projection 200 mm, shank fixing, flexible high pressure supply tubes 3/8 inch with metal body with DVGW / KIWA / WRAS / CSTB length 800 mm, nozzle height 125/157 mm, overall length 142/172 mm, ceramic cartridge with hot water safety device Ø 35 mm, for installation below the window, remaining height at the base 25 mm, for borehole diameter Ø 35 mm, for pressure type water heater, for continuous line heater, PN 10,

Product picture



Dimensional drawing

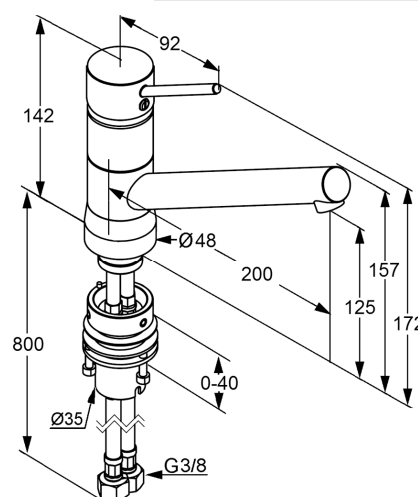

Flow rate diagram

